

*INSTALLATION MANUAL*

# MEC-HL COMPACT

Electromechanical proportional actuators  
for Hydraulic Applications



  
**HETRONIC**  
A METHODE ELECTRONICS COMPANY

# Table of Contents

Legal Disclaimers, Copyright, Disclaimer, Safe system use, Customer Service Contact Information....3/4

About this Manual, Your Manual, System Number.....4/5

Introduction, Hetronic Innovation: MEC-HLC, Technical Information.....5/6

Installation Procedure, Phase 1: Positioning the Actuators.....6/7

Phase 2: Placement of the Receiver.....8

Placement of Key Switch Box.....9

Phase 3: Connection Cable, Cable Positioning, Parts of Cable.....9/10/11

Phase 4: Power Connections.....12/13

Phase 5: Safety Valve Connection.....13/14

Phase 6: Adjustment and Settings.....15/16/17

Hetronic Receiver Configuration.....18/19/20

Mechanical Kit.....21/22

Optional Accessories (Easy Kit).....23/24/25

# List of Figures

**Figure 1.** System Number Label.....5

**Figure 2.** Actuator installation and **Figure 3.** Close-up of the actuator.....7

**Figure 4.** Placement of the Receiver.....8

**Figure 5.** Placement of the Key Switch Box.....9

**Figure 6.** Output cable drawing for RX14-HL ADM-6 (6 Functions).....10

**Figure 7.** Receiver RX14-HL ADM-6.....10

**Figure 8.** Output cable drawing for RX DC-Mobile (4 functions) and **Figure 9.** Receiver DC-Mobile .....11

**Figure 10.** Power Connections.....14

**Figure 11.** Power\_Control Cable for MEC-HLC .....15

**Figure 12.** Wiring Connections of NA Relay Box - limit device existing .....16

**Figure 13.** Wiring Connections of NA Relay Box with valve mounting .....16

**Figure 14.** NOVA-L 6L Transmitter layout and **Figure 15.** NOVA-L 6L Transmitter .....17

**Figure 16.** NOVA-L 4L Transmitter layout and **Figure 17.** NOVA-L 4L Transmitter.....18

**Figure 18.** DC-Mobile Receiver Configuration Software.....21

**Figure 19.** ADM Receiver Configuration Software .....22

**Figure 20.** Standard 4 Position Bracket.....23

**Figure 21.** Standard 6 Position Bracket.....23

**Figure 22.** Universal Assembled Clamp .....24

**Figure 23.** Universal 4 Position Bracket and **Figure 24.** Universal 6 Position Bracket.....25  
**Figure 25.** HS-1 Receiver Kit Support and **Figure 26.** HS-2 Receiver Kit Support.....26  
**Figure 27.** Key Switch Support and **Figure 28.** Bracket One Position.....27

## List of Tables

**Table 1.** Technical Information.....6

## IMPORTANT INFORMATION

Please, Read the installation or operation of the Hetronic product  
Before to install or get the operation of this product.

The installer and operator are responsible for reading and understanding the Installation Manual  
they have to read it carefully and completely.

The Installation and Operator Manuals have to  
Provide the installer and operator with an understanding of the features and  
Important safety information regarding your Hetronic product. Keep manuals in an  
Accessible and secure location at all times and refer to them as necessary

## Legal Disclaimers and Copyright Information

### Disclaimer

All information in this manual is provided without any warranty to its correctness. The material on these pages reflects HETRONIC's best judgment in light of the information available to it at the time of its preparation. Any use which a third party makes of these pages, on any reliance on or decision to be made based on it, are the responsibility of such third parties. Hetronic accepts no responsibility for damages, if any, suffered by any third party as a result of decisions made or actions based on these pages.

Your system may be customized for your specific application, it is important to review and be aware of any and all custom configured modifications that may have been made to your specific system.

### Copyright information

Copyright © By Hetronic, Inc. Intl.

October 2016



**WARNING**

## Safety Information

The Hetronic system you purchased is a highly-engineered product and is of the highest caliber in remote control performance and safety. Improperly used, however, the MEC-HL C System can cause severe injury. Those who use and maintain this system should be trained in its proper use, warned of its dangers, and should read all manuals before attempting to set up, operate, or service the system. FAILURE TO FOLLOW INSTRUCTIONS AS TO THE SYSTEM'S INSTALLATION, OPERATION AND MAINTENANCE CAN RESULT IN PERSONAL INJURY, DEATH AND/OR PROPERTY DAMAGE.

Those who install, use and maintain this system should be properly trained, including being knowledgeable as to its dangers, and should read all manuals before attempting to set up, operate, or service the system. Proper maintenance and regular inspection of the system is critical to the safe operation of the system. Buyer specifically acknowledges that it is aware of the risks of using a Hetronic product if the product's housing becomes cracked or broken, including the risk of serious injury, death or property damage. In the event of a cracked or broken housing it is strongly recommended that the product not be used and Hetronic or its authorized service point be contacted for service of your system.

Ultimately, the operator is solely responsible for the safe operation of the system and any vehicles, machines or equipment operated remotely. The operator must be aware of his surroundings and all the related risks at all times.

## Customer Service Contact Information

For more information and/or service, contact us on our web site: [www.hetronic.com](http://www.hetronic.com)

*Hetronic Dealer:*



## About this Manual

Thank you for purchasing the Hetronic MEC-HL C Actuator system. Hetronic radio remote controls provide outstanding remote control value, quality, performance, and safety. This manual is intended to be used for product installation; refer to the Operator manual for information about system operation. A separate Operator's manual provides the information needed for the person who will be operating the system.

## Your Manuals

Each MEC-HL C System has been specifically configured for your application. Before installing your MEC-HL C and Operator's Control Unit, review your drawings and read the manuals for all of your system components.

### System Numbers

Before contacting your dealer or Hetronic about service, repair, or replacement parts, note the equipment System numbers. These numbers are located on the label affixed to the unit.



**Figure 1.** System Number Label

### Safety Alerts

The safety alert symbol is used in decals on the unit and with proper operation procedures in this manual.

Understand the safety message. It contains important information about personal safety on or near the unit.



**DANGER**

*IMMINENTLY HAZARDOUS SITUATION! If not avoided, WILL RESULT in death or serious injury.*



**WARNING**

*POTENTIALLY HAZARDOUS SITUATION! If not avoided, COULD RESULT in death or serious injury.*



**CAUTION**

*POTENTIALLY HAZARDOUS SITUATION! If not avoided, MAY RESULT in minor or moderate injury. It may also be used to alert against unsafe practices.*

### Notations

*NOTE: General reference information for proper operation and maintenance practices.*

*IMPORTANT: Specific procedures or information required to prevent damage to unit or attachment.*

## Introduction

The new HETRONIC MEC-HL C Actuator is an innovative electronic modification kit designed to improve efficiency and safety on any hydraulic application. This manual should only be used as a guideline for the installation of actuators on end-customer applications. Hetronic recommends professional installations using experienced and trained personnel. For training contact Hetronic.

## Technical Information

POWER SUPPLY VOLTAGE	12 V or 24 V
CURRENT REQUIRED UNDER MAXIMUM STRESS	~ 1,9 A
PROTECTION CLASS	IP 65
MAXIMUM SPEED MOVEMENT	6 mm/s
NOMINAL VALUE OF TRANSMISSIBLE FORCE	200 N ( 44,96 lb )
ABSOLUTE VALUE OF TRANSMISSIBLE FORCE	350 N ( 76,68 lb )
MAXIMUM STROKE	25 + 25 mm ( 1+1 inch )
MAXIMUM TOLERABLE AXIAL LOAD	400 N ( 89,92 lb )
MAXIMUM TOLERABLE RADIAL LOAD	15 N ( 3,37 lb )
AVERAGE MOVEMENT ACCURACY	0,1 mm ( 0,0039 inch )
OPERATING TEMPERATURE	-25° ÷ + 70°C ( -18° ÷ 160° F )
WEIGHT	1580 g ( 3,48 lb )
CONNECTION	Amphenol 6P+PE
TOLERABLE MOUNTING POSITION	0° ÷ 360°
EXTERNAL DIMENSIONS	44 x 182 x 82 mm ( 1,73x7,16x3,22 inch )
LOCKING TO STEM	M8
LOCKING HOLES	N°2 M6x10

*Table 1. Technical Information*

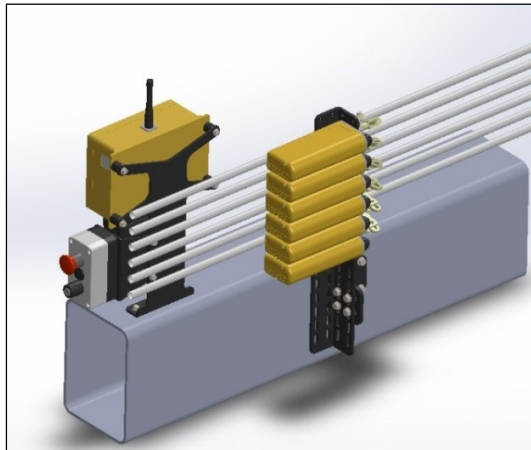
## Installation Procedure

### PHASE 1

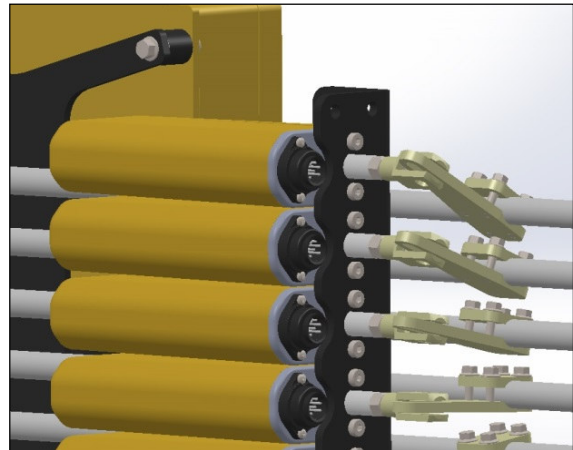
#### Positioning the Actuators

1. Choose a point close enough to the hydraulic distributor to fix the mounting brackets, ensuring that the movements of the machine won't interfere in any way with the new parts applied.
2. The actuator mounting brackets provided with the actuator installation kit must be assembled to a surface that has a thickness of at least 10 mm and a width of at least 60 mm.
3. The bracket should be well fixed to the truck structure, free from any mechanical bending or distortions. Bolting is preferable to welding (operation however allowed in those cases in which there aren't the conditions to avoid it). The mounting and installation might take a longer when using bolts. However there are many benefits during initial setting up of the installation and its maintenance when taking the bolt fixing approach.

The following pictures show some installation cases. Pictures are intended for illustration purposes only. "Since various truck manufacturers exist and trucks from same manufacturer tend to vary as well, it is recommended to consider each installation a new case by itself".



**Figure 2.** Actuator installation towards one of the existing lever rod mechanism



**Figure 3.** Close-up of the actuator linkage end assembly

## NOTES

1. Carefully align the mechanical support for the actuator assembly before it is tightened in place using M6 bolts. The rods should slide freely and with some residual backlash. It is always recommended to fix the brackets from one end before fixing one or more motors and connecting them to the corresponding forks and clamping them to the transmission rods. Once the optimum alignment is reached, complete the final fixing.
2. Actuators have a springs return to centre position. It's important to lock the clamp on the rod of the double commands only after having bounded it to the actuator. In this way the neutral position of the motor will correspond exactly to the one of the distributor, ensuring a correct return to 0 position and with the totally available on both the directions of movement.
3. The fixing kit includes 5 mm bolts with self-locking head properly tightened during the assembly of the mounting brackets to prevent the accidental loosening of mounts.

## IMPORTANT

Any accidental loosening could considerably alter the radio control function and/or damage the mechanical assembly.

4. Applications which do not require multiple motors installed in parallel on same mounting bracket offer a higher degree of flexibility during installation. Each motor can be aligned accurately along the direction of the force to be applied in order to ensure precise and reliable movement.
5. The new design of the MEC-HL-C actuators, thanks to a further reduced cross-section, facilitates the positioning in situations where the space is drastically reduced.

- An optional universal KIT, (Easy Kit), can be used in the direct application on the levers. Special dowels are inserted on the base of each lever. Connections between these dowels and the forks on the modules are done by a set of connecting rods designed and made based on the machine specifications. The goal is to compensate the centre-to-centre distance difference between the various levers and the set of modules, along with the need to convert an angular motion (lever) into a linear motion (module). The connecting rods are manufactured with an offset between the two sockets to distribute the centre-to-centre difference progressively. As a result the misalignment will be extremely reduced thus ensuring smooth operation.

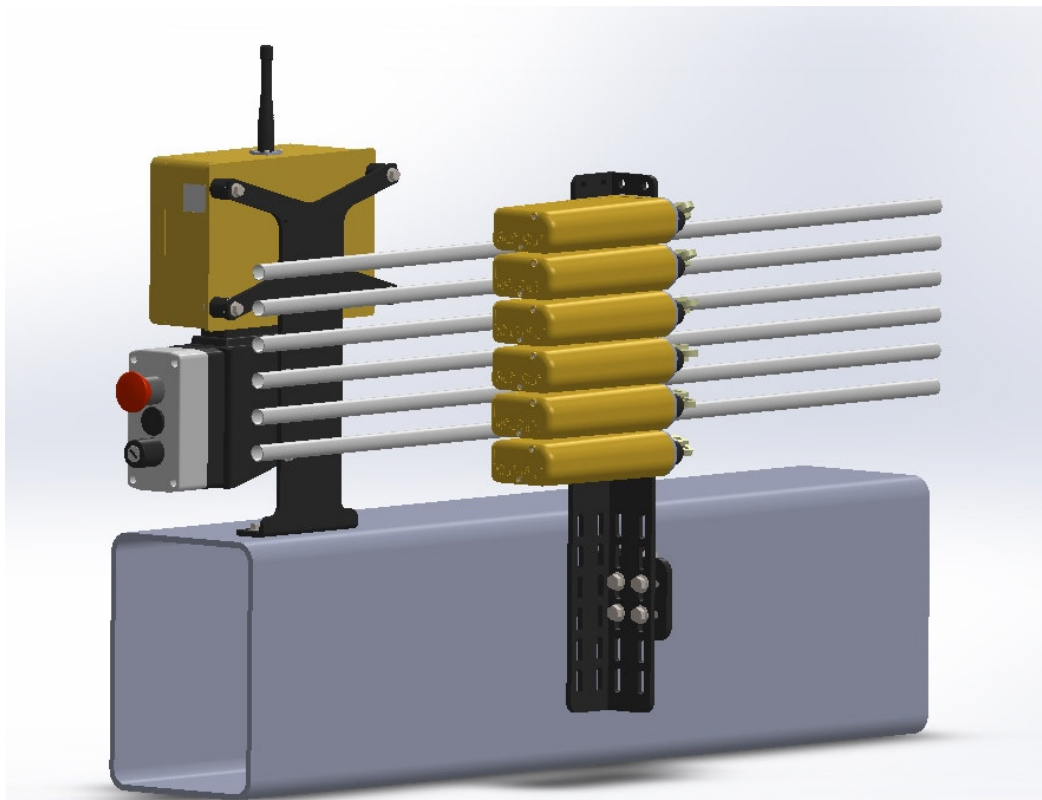
## PHASE 2

### Placement of the Receiver

The receiver should be placed in an open space on the edge of the truck avoiding close proximity or interference with the back of the vibrating cabin or the deck. The support seating of the receiver must be such that a minimum of 150 mm along the 70-pole / 30pol connector area is available to facilitate assembly and removal of same connector.

The receiver should be placed allowing the diagnostic LED's to be completely visible by the operator.

Hetronic can provide as optional the supports of the receivers.



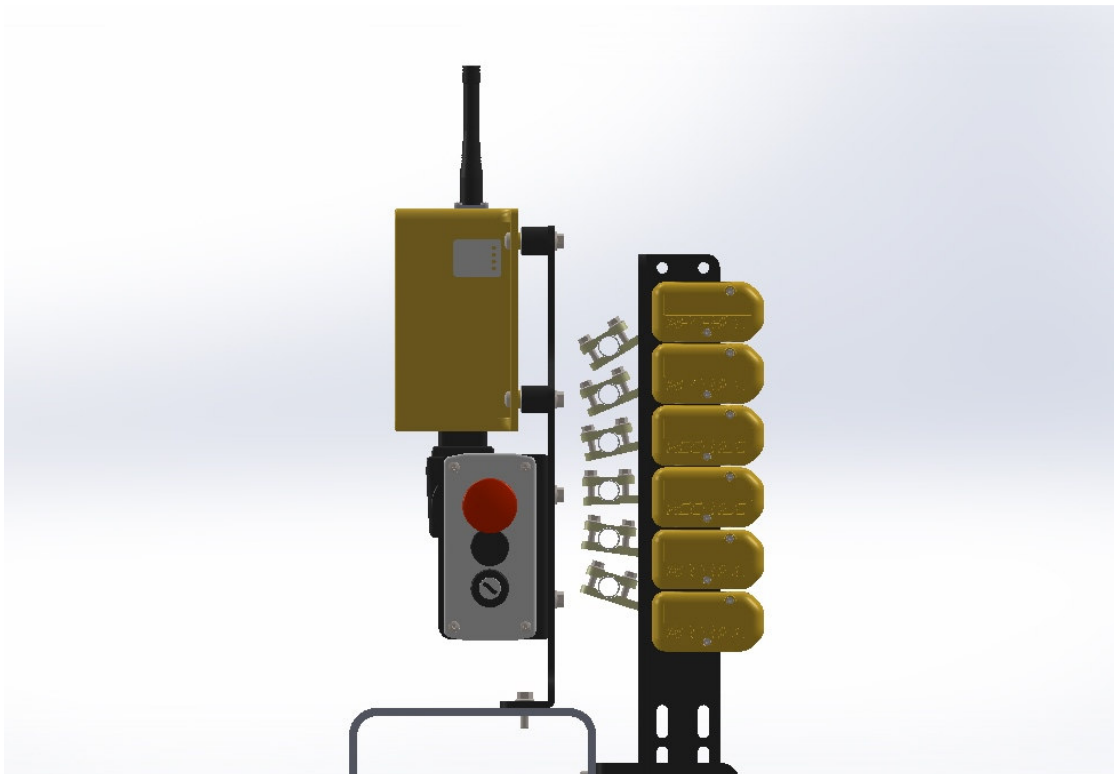
**Figure 4.** Placement of the Receiver



## Placement of the Key Switch Box

It is possible to use the same seating to mount the STOP button and the operation selector radio or manual unit, which are part of the supplied wiring.

The STOP button has to be placed so that it can be easily activated by the operator in the event is necessary to turn off the receiver.



*Figure 5. Placement of the Key Switch Box*

## PHASE 3

### Cable Positioning

There is enough cable length provided in the MEC-HL kit to reach all of the connection points of the different devices on the truck.

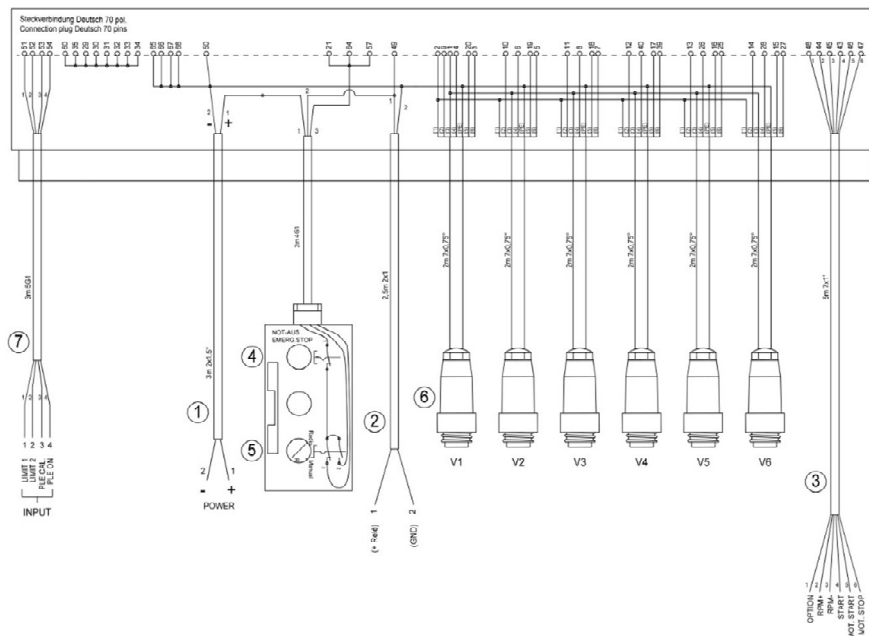
Note in the figure the possibility to mount the actuators also with independent positioning and separated brackets.

This flexibility is sometimes the only way to reach a proper end result.

## Parts of Cable

The cable consists of:

- 1) 12 or 24V POWER SUPPLY
- 2) 12 or 24V OUTPUT FOR THE NA CONTROL (OR OIL DRAIN SAFETY VALVE)
- 3) A MULTI-POLE CABLE FOR THE AUXILIARY FUNCTIONS CONTROL
- 4) STOP BUTTON
- 5) RADIO/MANUAL SELECTOR
- 6) SERIES OF CONNECTORS TO CONTROL THE MEC-HL C ACTUATORS
- 7) A MULTI-POLE CABLE FOR THE LIMIT INPUTS (WHERE AVAILABLE – ADM SYSTEMS)



**Figure 6.** Output cable drawing for RX14-HL ADM-6 (6 Functions)



**Figure 7.** Receiver RX14-HL ADM-6

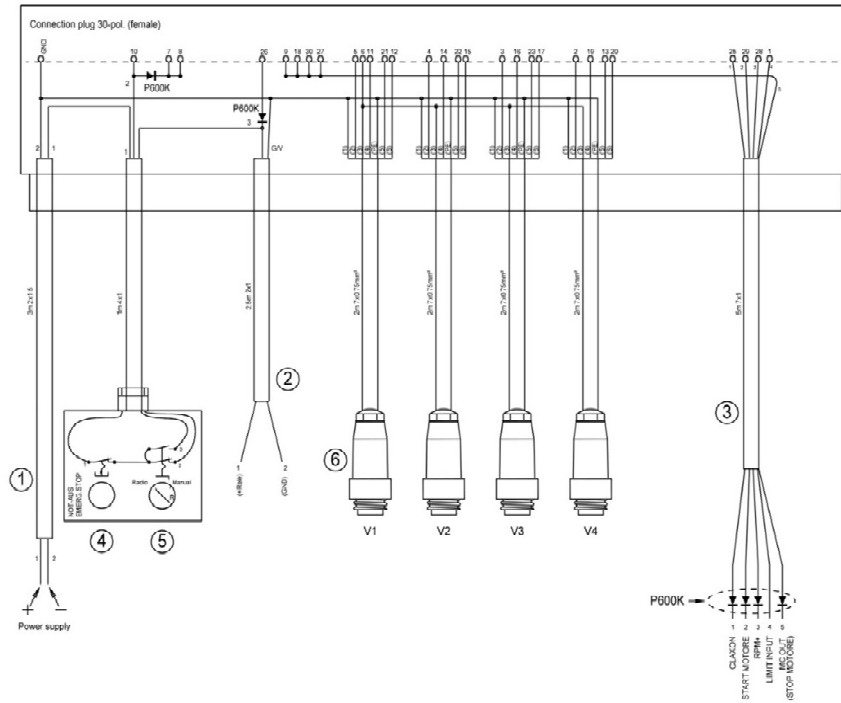


Figure 8. Output cable drawing for RX DC-Mobile (4 functions)



Figure 9. Receiver DC-Mobile

## Phase 4

### Power Connections

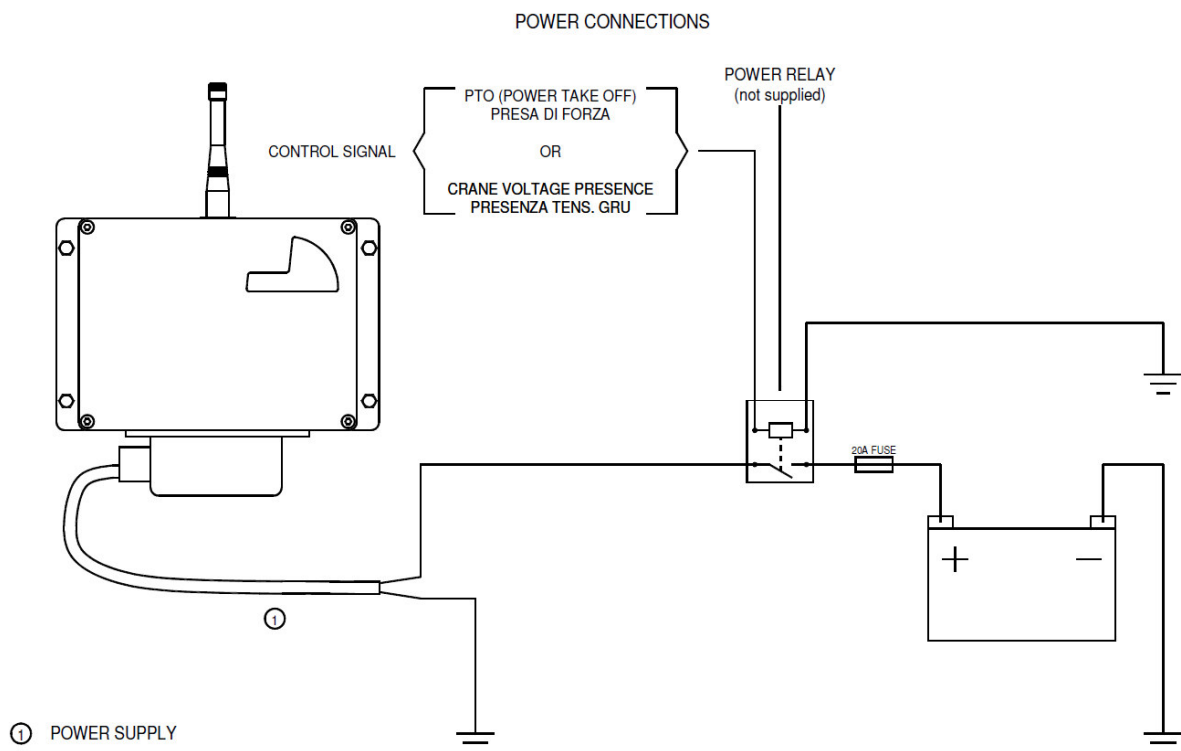
Power supply is taken from the main battery of the vehicle, with the positive wire connected through a power relay (suggested 20 A) whose control signal can be the PTO (Power Take Off) of the vehicle or the crane voltage presence.

Cable marked “+ and –“supplies the general power to the radio control.



**WARNING**

*Positive poles have to be protected with a 20A fuse.*

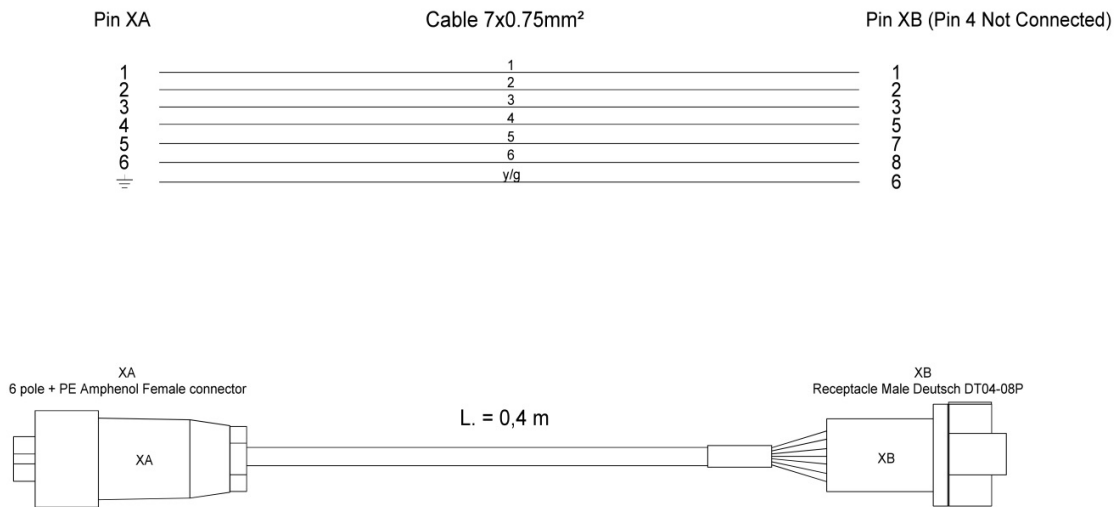


**Figure 10.** Power Connections



**WARNING**

When replacing a 1000C actuator (this is 12V only) or MEC-HL with a MEC-HL-C actuator, choose the version with the supply voltage matching the one of your plant. A special optional power control cable allows the compatibility of the new 6P+PE Amphenol connector with the Deutsch connector of the previous plants.



**Figure 11.** Power Control Cable for MEC-HLC

## Phase 5

### Safety Valve Connection



**WARNING**

The cable with NA label plate controls the general safety valve. It ensures that the hydraulic circuit holding the oil between the pump and hydraulic distributor under pressure is open. This means that the crane moves only when this valve is energized. When voltage is present, the valve closes keeping oil pressure constant. Pressing any emergency button on the machine results in an immediate fall of such voltage as well as in an immediate shut-off of all the crane functions.

The valve **MUST** be mounted and connected to the radio control NA cable. This applies to older crane models as well as newer models.

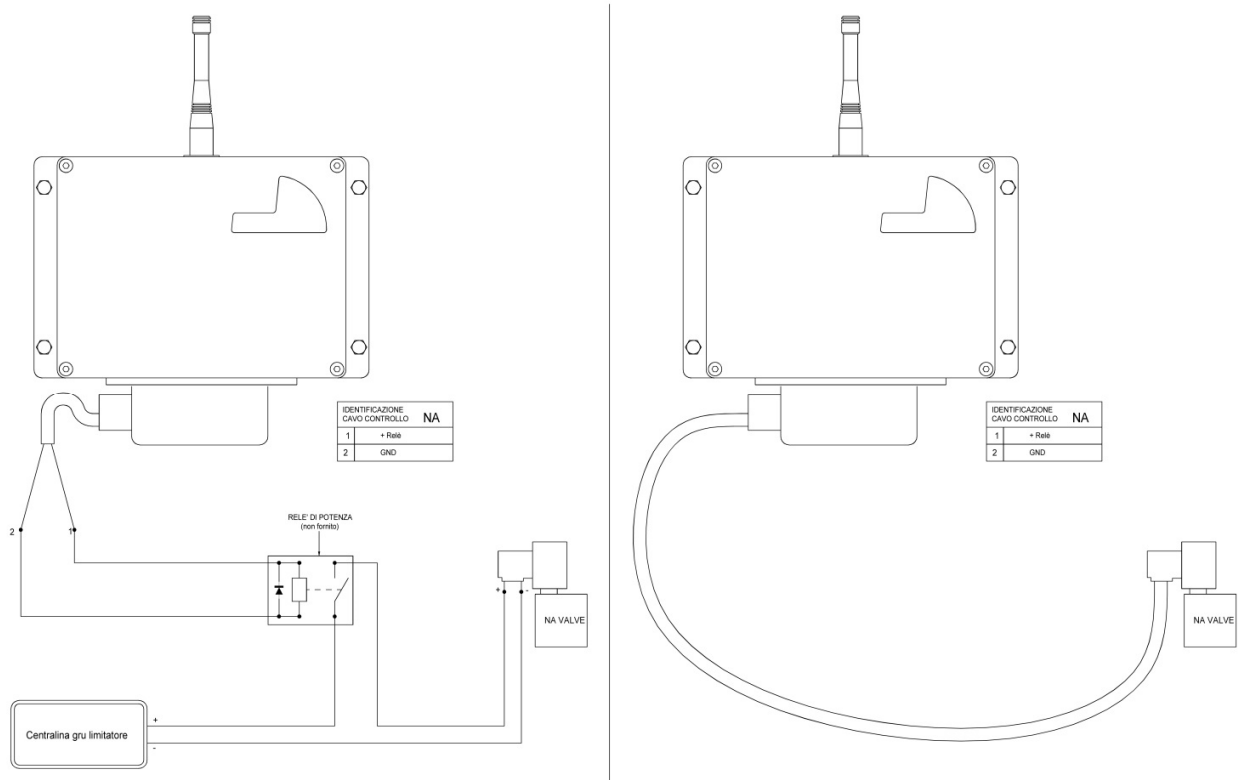
 **WARNING**

Failure to follow the instructions above indicated in Phase 5, "Safety Valve Connection", can seriously compromise the safety conditions required by the Norms.

The most common installations are the following:

1. The crane main valve is directly controlled by the crane limiting controller if existing, with a power relay to close the electrical circuit when the NA output of the receiver is activated.
2. The crane main valve is directly connected to the NA output of the receiver, if the crane doesn't have a limiting controller.

The following picture shows the possible connection options to control the NA valve.



**Figure 12.** Wiring Connections of NA Relay Box – limit device existing

**Figure 13.** Wiring Connections of NA Relay Box with valve mounting

## Phase 6

### Adjustments and Settings

It is necessary for the installer or operator to adjust the stroke that each actuator will make to move each element of the hydraulic distributor. This is necessary since the mechanical stroke required to open the distributor valve has an unknown value and varies between different crane models and manufacturers. Slight differences may exist between one valve and another on two identical trucks. Final adjustments of installation are made using the transmitter model used in your application.

The following drawings show the main transmitter models that can be used.

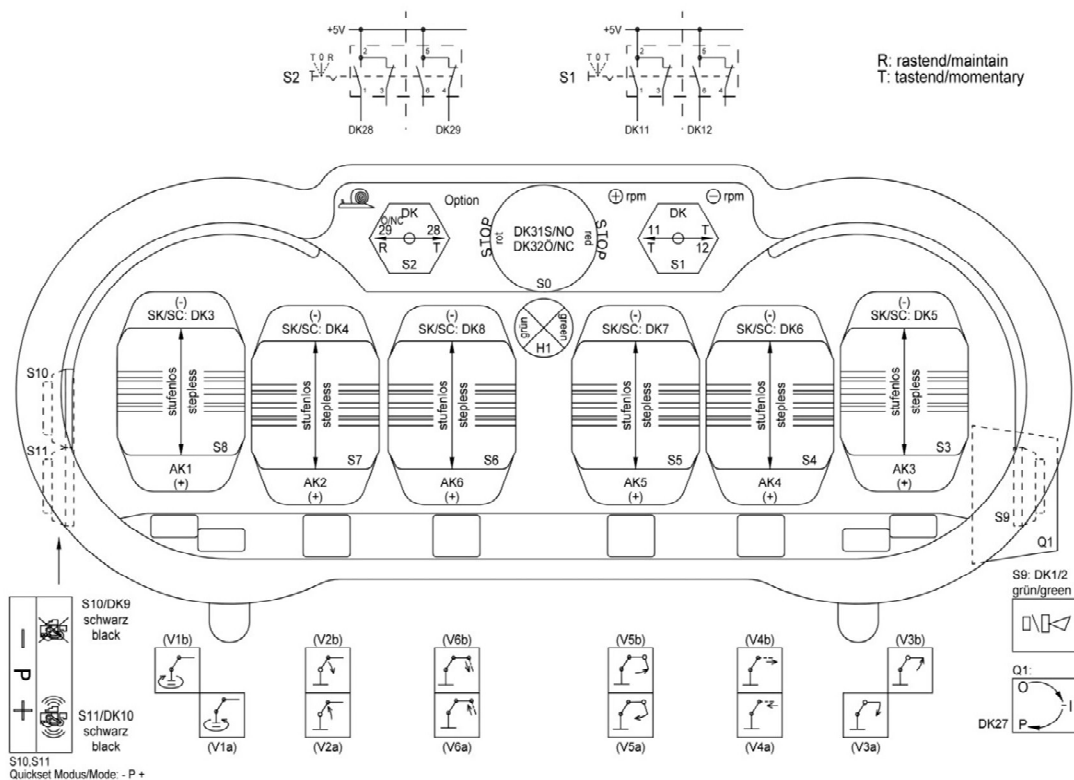


Figure 14. NOVA-L 6L Transmitter layout



Figure 15. NOVA-L 6L Transmitter

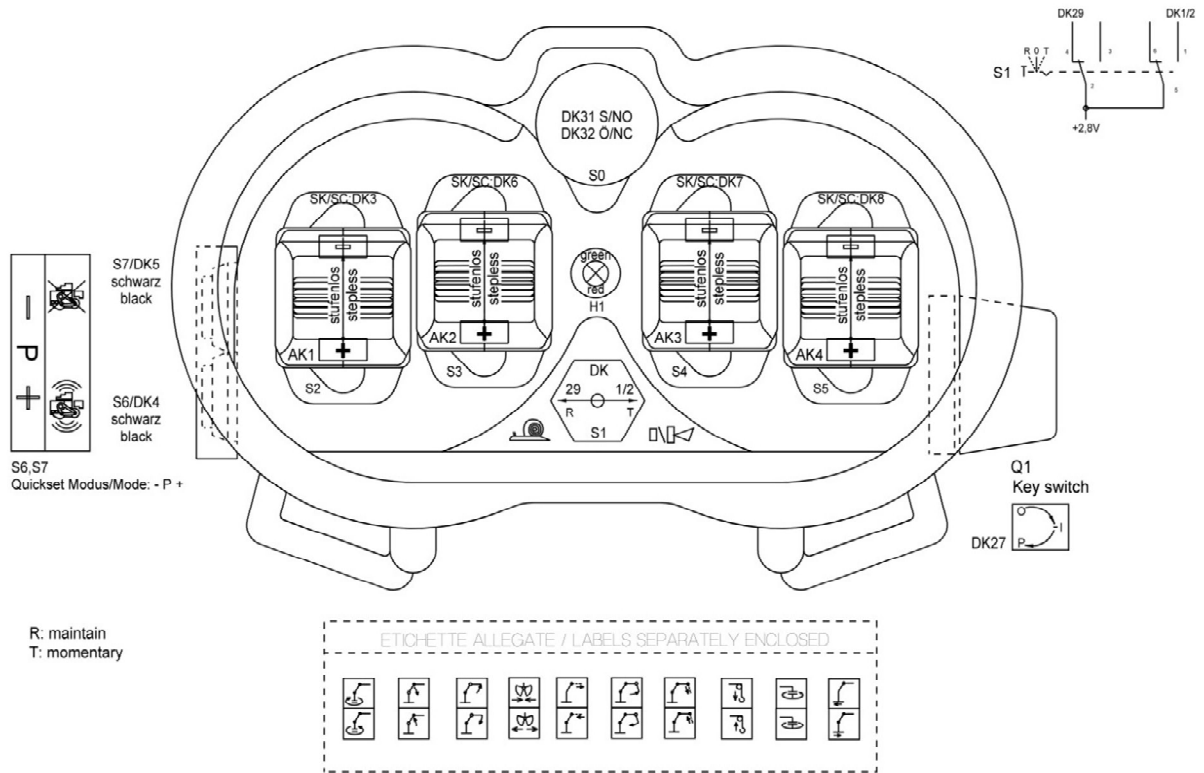


Figure 16. NOVA-M 4L Transmitter layout



Figure 17. NOVA-M 4L Transmitter



The following steps should be followed for final adjustment of the installation.



**CAUTION**

*Adjustments can only be done by using the RED Key on the Transmitter; the BLACK Key will not allow the operator to make adjustments or changes to the setup.*

*Red Key should only be handed out to personnel trained to make adjustments or changes to setup of the system.*

1. Provide a supply to the equipment: receiver powered, RADIO/HAND selector put in the Radio position, STOP button released and joysticks / switches in their neutral position.
2. Check that the first yellow LED on the receiver side (OPERATION) is on and flashing regularly.
3. Insert the red programming key into the transmitter.
4. Turn on the transmitter (first click of the key). The green LED on the receiver side will start flashing regularly after approx. 3 seconds. The yellow LED (NORMAL) on the receiver side will turn on and stay lit up. This means that regular operation is ready, the system is in safe mode and the radio control is ready to be engaged.
5. Press the start button (green button on Transmitter, check drawing of position on different Transmitter types). Each actuator moving the corresponding section of the hydraulic distributor should be adjusted individually and according to the running direction.



**DANGER**

*During phases 6/7, is highly recommended to perform this operation with the truck engine turned off.*

6. After positioning the red key in to the Key switch Q1 turn Key into second Position "P", press the joystick of the function to be adjusted to the end-of-travel. The lever of the actuator should move to a generic point along the stroke.
7. Press and release the "P+ or P-" key (PB or TS), repeat action till you achieve the desired maximum speed / stroke setting. The maximum stroke of the Joystick should reflect 100% the mechanical stroke of the valve and never exit the same. If electrical set value from RRC is higher than the mechanical stroke of Valve the Motor will open the internal MEC-HL clutch and brings the motor back in central position.

**WARNING**

*During the programming phases of each actuator, it is important to verify that this movement occurs without any residual mechanical stress between the actuator and the valve mechanical limit switch. Long-term damage to the linkage mechanism or the actuator itself may result if unwanted mechanical stress demonstrated by bent or deformed rods or strange noise during actuator movement is noted. It is recommended to push button “P+ or P-” until any residual stress is eliminated completely and the actuator mechanism is moving smooth.*

8. Once this initial adjustment step is over, the stroke start value should be set. Move the joystick from its neutral position, until the first reaction of the actuator is noted. Press and release the “P+ or P-” key (PB or TS), repeat action till you achieve the desired initial speed / stroke setting. Repeat the point 7 and 8 individual on all Joysticks / MEC-HL Motors
9. At the end of this operation, change Red key to Black key and check that the crane function does not move before the joystick is out of its initial position or exits the maximum stroke of mechanical valve. Engine of vehicle should be running now and rpm (Gas) setting should be set to its usual operation speed. In case final changes have to be made insert Red key again and use the “P+ or P-” button to make final setup changes.

## HETRONIC RECEIVER CONFIGURATION

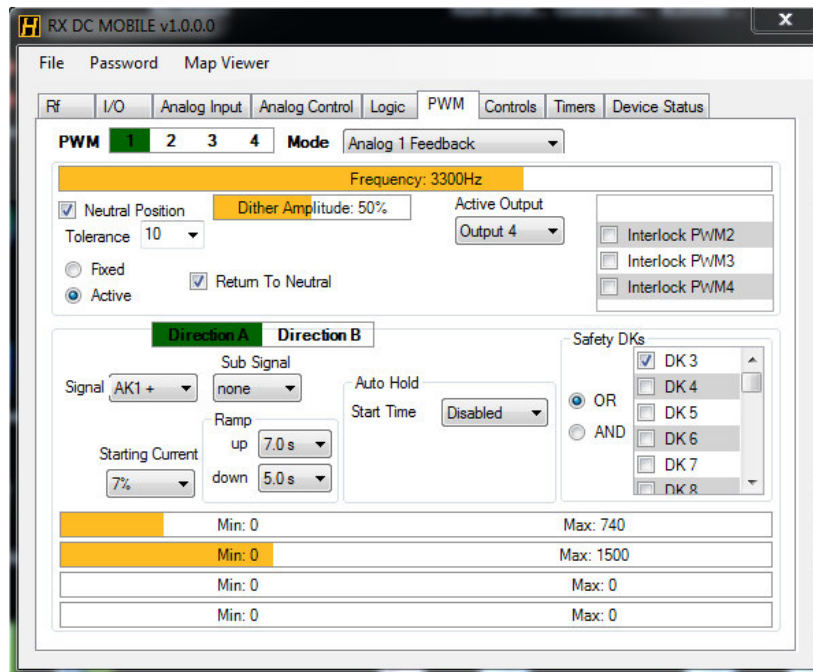
Hetronic receivers have a factory default configuration that is not electrically driving the actuators back to neutral position. The default configuration is not monitoring the position of the actuator when it returns back to neutral, modifications to these setting are possible but should only be made by trained and authorized personnel.

Monitoring the Actuator out of Neutral Position

DC Mobile Receiver Hetronic H-Link tool, available as an option, is required. Only for trained and authorised personnel.

## STEPS FOR USE OF H-LINK TOOL

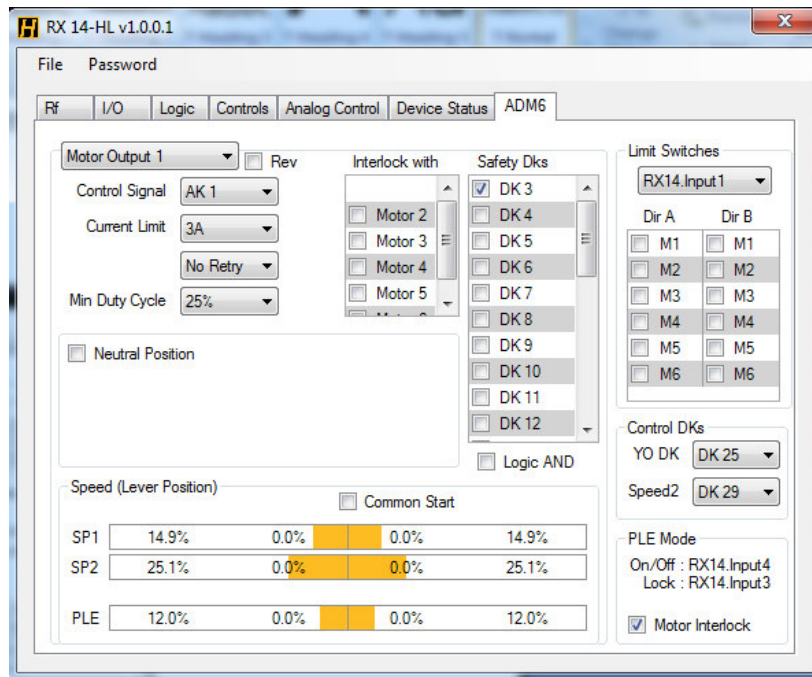
- a. Connect DC Mobile receiver to computer using micro-USB cable and launch PC H-Link software.
- b. Once connected to receiver, select PWM tab.
- c. Enable the Neutral Position checkbox.
- d. Set tolerance value on actuator neutral position. A small tolerance value requires high mechanical precision of actuator installation.



**Figure 18.** DC-Mobile Receiver Configuration Software

RX14-HL ADM-6 Receiver Hetric H-Link tool, available as an option, is required. Only for trained and authorised personnel.

- a. Connect RX14-HL ADM-6 receiver to computer using micro-USB cable and launch PC H-Link software.
- b. Once connected to receiver, select ADM6 tab.
- c. Enable the Neutral Position checkbox.
- d. Set tolerance value on actuator neutral position. A small tolerance value requires high mechanical precision of actuator installation.



**Figure 19.** ADM Receiver Configuration Software

 **WARNING**

*The Neutral Position applies for actuator applications where a neutral position is kept. It is the position of the potentiometer feedback when the control AK signal is in neutral or the safety DK assigned is not active. If there is no neutral position, the reference neutral position will always be changed to the position while the control AK signal is neutral.*

*When the neutral position is selected fixed, the neutral position must be specified manually or automatically memorized after an H-Link update.*

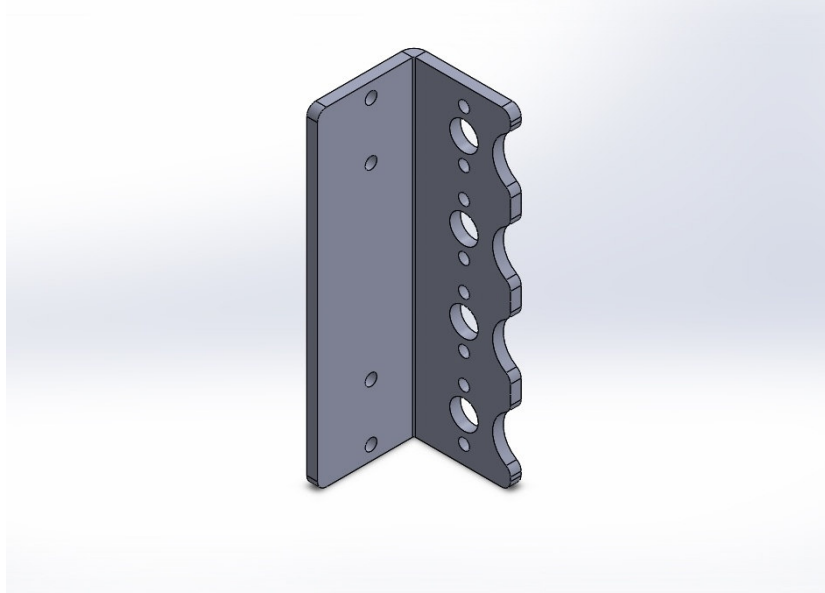
*When the neutral position is selected Active, the neutral position is automatically renewed every power ON reset condition. In this case the receivers check that the actuators go back to the neutral position when the control AK signal is in neutral. If the actuators remain out of neutral position while the control AK signals are neutral, it will release the control of the actuators and will be in Manual status until a valid neutral is verified for all enabled PWM outputs.*

*By activating Return to Neutral option, The Hetric receiver will control the actuator in returning to neutral position and release after a valid neutral is verified.*

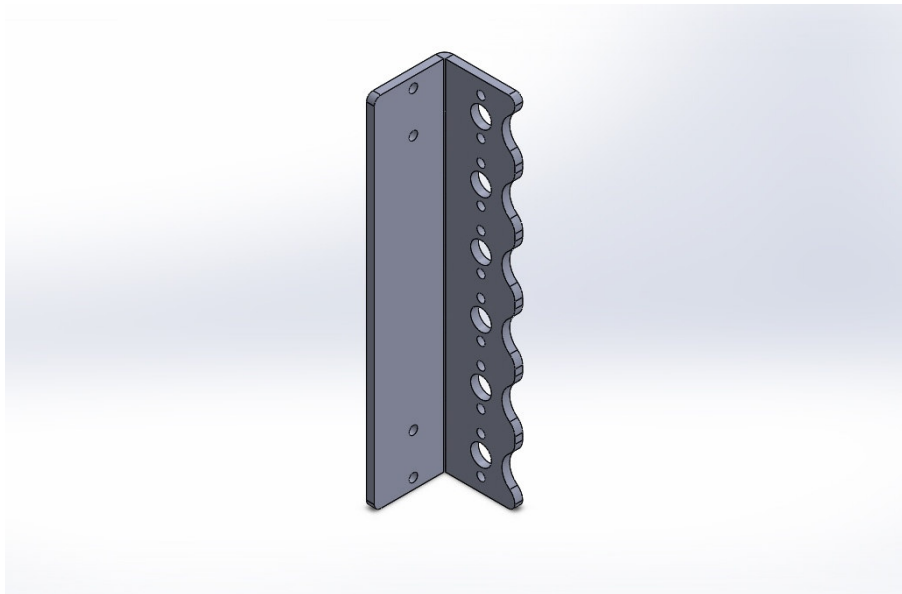
 **WARNING**

*Any changes to the setting files have to be saved and it is the full responsibility of the person performing the changes that they are made in accordance to the worldwide norms of safety to avoid any dangerous or uncontrolled action by the user.*

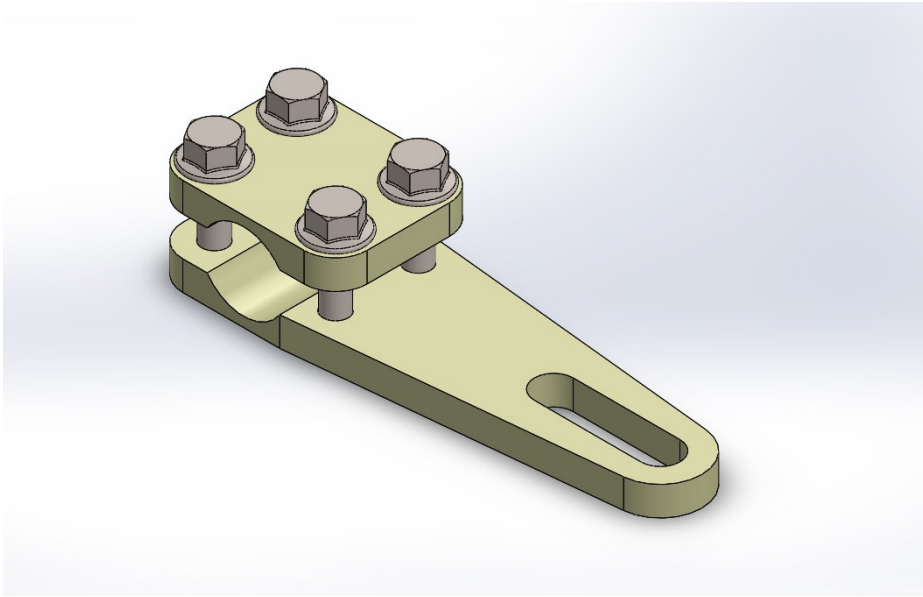
## Mechanical Kit



**Figure 20.** Standard 4 Position Bracket

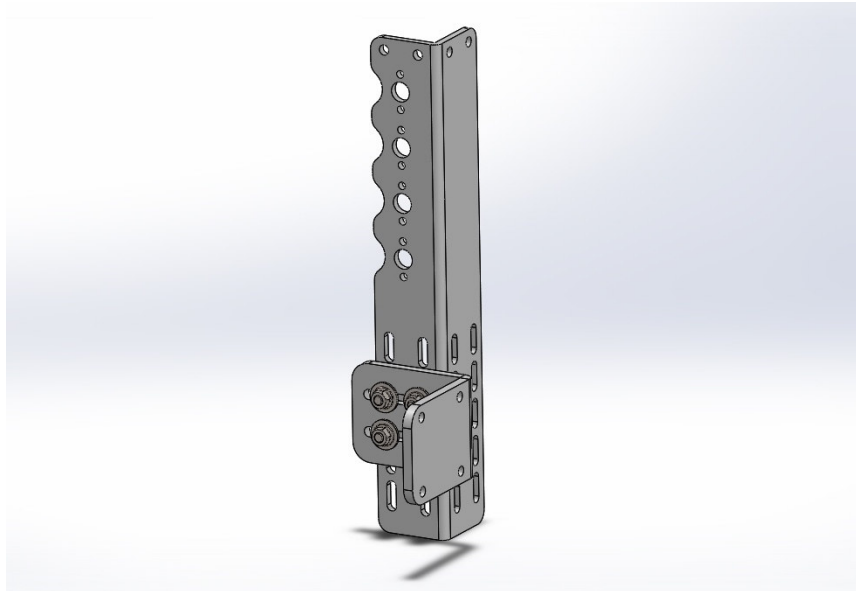


**Figure 21.** Standard 6 Position Bracket

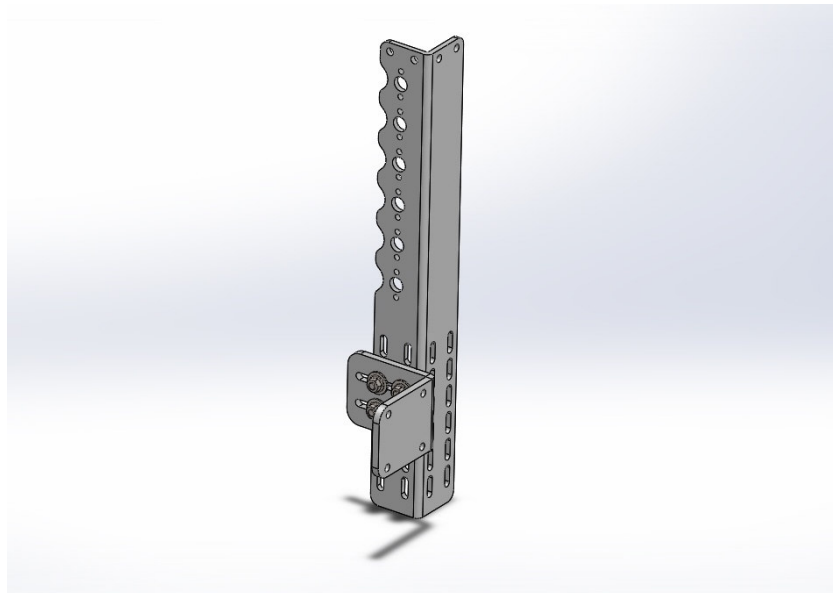


**Figure 22.** *Universal Assembled Clamp*

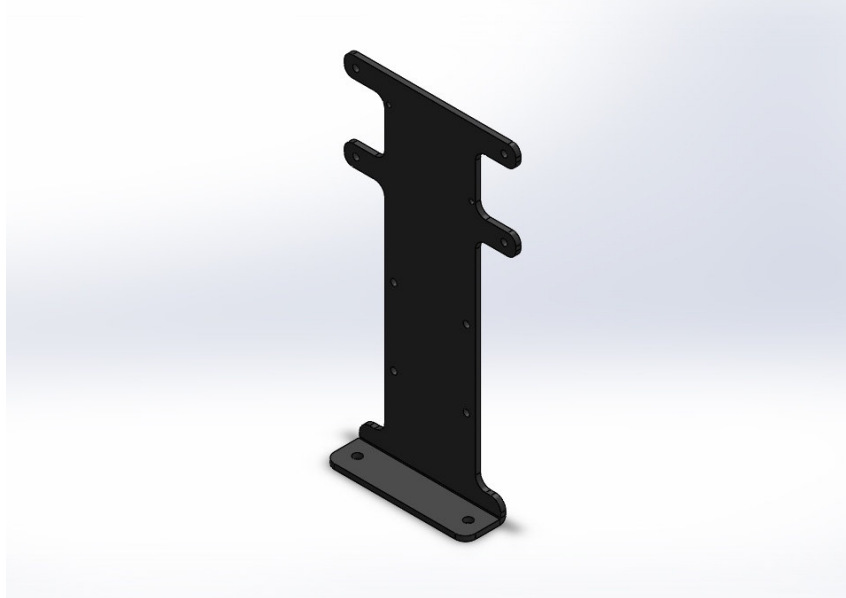
## Accessories Optional (Easy Kit)



**Figure 23.** Universal 4 Position Bracket



**Figure 24.** Universal 6 Position Bracket



**Figure 25.** *HS-1 Receiver Kit Support*



**Figure 26.** *HS-2 Receiver Kit Support*





**Figure 27.** *Key Switch Support*



**Figure 28.** *Bracket One Position*

