



**HETRONIC**

# Operator Manual Ergo Systems



**Ergo V1**



**Ergo V2**



**Ergo V4**



**Ergo V5**



**Ergo V7**



**Ergo V8**

[www.hetronic.com](http://www.hetronic.com)

**YOUR #1 PARTNER IN RADIO REMOTE CONTROLS**

**Hetronic USA**

4300 Highline Blvd., Bldg. A  
Oklahoma City, OK 73108  
405-946-3574 Fax 405-946-3564

**Hetronic Canada**

45 Sinclair Avenue  
Halton Hills, Ontario L7G 4X4  
+1-800-816-4459 Fax +1-905-702-0501

© 2004 Hetronic, Inc.

All rights reserved. No part of this publication may be reproduced, transmitted, transcribed, stored in a retrieval system, or translated into any language in any form by any means without the written permission of Hetronic.

OPMN\_ERG\_0001.0  
6/04

# TABLE OF CONTENTS

<b>Introduction</b> .....	<b>3</b>	ERGO V7. ....	18
The Manual .....	3	ERGO V8. ....	19
Production and System Numbers .....	3	<b>Transmitter Setup</b> .....	<b>19</b>
Unauthorized Replacement Parts .....	3	<b>Test Procedures</b> .....	<b>20</b>
Before Attempting to Operate This System ...	3	Test the System .....	20
Hetronic System Components .....	4	LED Designations & Layout .....	20
Receiver Standard Features .....	4	<b>Operation</b> .....	<b>21</b>
Transmitter Standard Features .....	4	Holding the Transmitter .....	21
Transmitter Specific Features .....	4	Visual Check .....	22
System Overview .....	4	Start-Up Procedure .....	22
Theory of Operation .....	4	To Stop In An Emergency .....	22
E-Stop Function .....	4	Safe Mode .....	22
Transmitter Sleep Mode .....	4	<b>Maintenance</b> .....	<b>23</b>
Receiver Safe Mode .....	4	Changing the Battery .....	23
<b>Safety</b> .....	<b>5</b>	Changing the Battery Adaptor .....	23
Safety Alerts .....	5	Optional Rechargeable Battery Pack ...	23
Notations .....	5	Battery Disposal .....	23
Practices and Laws .....	5	Optional Battery Charging System .....	23
Required Operator Training .....	5	Features .....	23
Safety Rules .....	5	The Battery Charger .....	23
Possible Sources of Danger .....	5	Fast Charge .....	24
Operation and Work Area Safety .....	5	Hetronic Battery Information .....	24
Protective Features .....	5	<b>RF Modules</b> .....	<b>25</b>
To Stop In An Emergency .....	6	Description of Functions .....	25
Maintenance and Storage .....	6	Setting the Frequency Channel .....	25
<b>Receiver Installation</b> .....	<b>6</b>	CS 458 RF-Synthesizer .....	26
Receiver Components .....	6	CS 447 RF-Synthesizer .....	27
Receiver Location .....	7	CS 434 RF-Synthesizer .....	28
Mounting the Receiver .....	7	STD-402 RF-Synthesizer .....	29
Receiver Mounting Dimensions .....	7	CS 429 RF-Synthesizer .....	30
GainFlex Antenna Installation .....	8	<b>Troubleshooting</b> .....	<b>31</b>
Standard External Antenna Installation ...	8	<b>Specifications</b> .....	<b>34</b>
Connect Electrical Wiring .....	8	<b>Installation / Safety Data Sheet</b> .....	<b>36</b>
Receiver Outputs .....	9	<b>Definitions &amp; AWG Metric Conversions</b> .....	<b>37</b>
Overhead Traveling Crane (Mat. Handl.) ...	15	<b>Abbreviations</b> .....	<b>38</b>
<b>ERGO Transmitters</b> .....	<b>16</b>	<b>Warranty</b> .....	<b>39</b>
Frequency and Address Settings .....	16		
ERGO V1 .....	16		
ERGO V2 .....	17		
ERGO V4 .....	17		
ERGO V5 .....	18		

# INTRODUCTION

## INTRODUCTION

Thank you for purchasing the Hetronic radio remote control system. Hetronic radio remote controls are the highest caliber in remote control value, performance and safety.

Hetronic radio remote controls use the latest frequency synthesizer technology to eliminate the problems typically associated with radio remote control systems.

## THE MANUAL

Before operation of the crane/machine and remote control system, read your manuals carefully and completely. The contents of this manual will provide you with an understanding of safety instructions and controls during normal operation and maintenance.

## PRODUCTION AND SYSTEM NUMBERS

When contacting your dealer or Hetronic about service, repair or replacement parts, know the Production and System numbers of the transmitter and receiver.

The numbers are located on the label that is affixed to the unit itself.

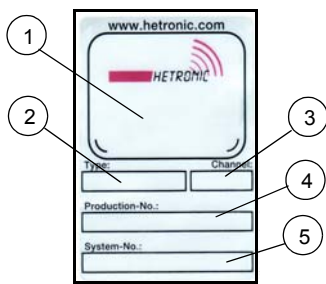

1. Specific approvals such as BTZ, FCC, CE, etc.
2. The type of transmitter or receiver.
3. Frequency and RF unit.
4. **Production Number** - The first digit indicates the manufacturing facility (1=H-Germany, 2=H-Malta, 3=H-US, 4=H-Italy). The next four digits are the production month and year. The last 6 digits are the system address.
5. **System Number** - The Hetronic Part Number of the transmitter or receiver.

Record the Production and System numbers here:

Transmitter Production Number

Receiver Production Number

System Number

## UNAUTHORIZED REPLACEMENT PARTS

Use only Hetronic replacement parts. The replacement of any part with anything other than a Hetronic authorized replacement part may adversely affect the performance, durability, and safety of this system and may void the warranty. Hetronic disclaims liability for any claims or damages, whether warranty, property damage, personal injury or death arising out of the use of unauthorized replacement parts.

## BEFORE ATTEMPTING TO OPERATE THIS SYSTEM:

1. Make sure all installation has been properly completed.
  2. ALWAYS be sure the crane/machine and radio remote control Emergency-Stop functions work properly before beginning any crane/machine operation.
  3. Understand all Safety Precautions provided in the manuals.
  4. Review control functions and operation of the machine and this radio remote control system.
  5. Surge suppressors (RC type only) must be used when the receiver is controlling magnetic contactors.
  6. When not in use, turn the transmitter off and store in a safe place to prevent unauthorized use.
  7. If the crane/machine does not respond properly, stop operation immediately. Turn off the transmitter and report the condition to the appropriate technician or supervisor.
  8. Turn off the transmitter and remove the battery before any maintenance work is done.
- IMPORTANT: AVOID SYSTEM DAMAGE - ALWAYS disconnect receiver power supply and control wiring before welding on any part of the crane/machine.**
9. Always have fresh batteries on hand or an optional rechargeable battery pack in the battery charger to ensure the availability of a fully charged battery.
  10. Installation, setup and service must be performed by authorized personnel only.
  11. Use only Hetronic spare parts.

## HETRONIC SYSTEM COMPONENTS

The Hetronic radio remote control system consists of a receiver and transmitter.

### Receiver Standard Features

Start/Horn relay, E-Stop relay, and option relay(s)

- Up to 14 digital outputs
- Self-diagnostics
- 48 V, 115 V or 230 V for AC cranes/machines
- 12VDC or 24VDC for DC cranes/machines

### Transmitter Standard Features

- E-stop switch
- Sleep mode
- Removable key power switch
- 100 m (300 ft.) range
- Internal antenna
- Wrist strap

## TRANSMITTER SPECIFIC FEATURES

### ERGO V1

- E-stop
- 6 single-speed pushbuttons

### ERGO V2

- E-stop
- Start/horn pushbutton
- 6 single-speed motion pushbuttons
- 5 single-speed option pushbuttons

### ERGO V4

- E-stop
- Start/horn pushbutton
- 6 2-speed motion pushbuttons
- 2 single-speed option pushbuttons

### ERGO V5

- E-stop
- Start/horn pushbutton
- 6 2-speed motion pushbuttons

### ERGO V7

- E-stop
- Start/horn pushbutton
- 6 2-speed motion pushbuttons
- 1 3-position slide selector

### ERGO V8

- E-stop
- Start/horn pushbutton
- 6 2-speed motion pushbuttons
- 2 latching single-speed option pushbuttons

## SYSTEM OVERVIEW

### Theory of Operation

The Hetronic radio remote control system includes a transmitter and receiver. The transmitter electronically generates a carrier frequency which allows it to communicate with the receiver.

These systems operate over the 400-470 MHz radio band range (70 cm band) and are FCC approved.

Each system is programmed with a unique address code. This code allows the operation of multiple systems in the same general vicinity.

The receiver only accepts commands from the transmitter with the same address code.

**NOTE:** The receiver and transmitter have the address code set at the factory.

### E-Stop Function

The most important feature of the radio remote control system is the E-Stop. The transmitter sends the E-stop status signal along with the specified crane/machine function. This method confirms that ongoing operations are safe. If the E-stop pushbutton is pressed, the E-stop relay in the receiver causes all crane/machine motions to stop. The receiver goes into Safe mode.

To restart the system, disengage the E-stop button and press the Start/Horn button.

The E-Stop responds faster than any other function. When E-Stop is engaged, the system ignores any other signal that is transmitted. The problem must be corrected before the system will respond to any other signal.

The E-Stop is self-monitoring and redundant in the transmitter and receiver. The system performs a self-test to ensure the E-Stop circuit is working properly. If an error is detected, the system automatically goes into Safe mode.

When the transmitter is turned on, it performs a self-test to be sure that communications are within designated parameters. If an error is detected, the transmitter will not transmit any signals.

### Transmitter Sleep Mode

The transmitter sleep mode is designed to prevent accidental operation. If the transmitter is not used for 10 minutes, it turns itself off. The controls are not operational while the transmitter is in sleep mode. To restart the transmitter, turn the key switch off and then back on, and press the Start/Horn button.

**IMPORTANT:** If the transmitter has a selector switch or latching pushbutton that is engaged, the sleep mode will not occur.

### Receiver Safe Mode

The following conditions cause the receiver to go into its Safe mode:

- The transmitter goes into Sleep Mode
- Radio signal interference
- Transmitter out of operating range
- E-Stop button is activated
- E-Stop circuit failure
- Low battery sends E-stop after time out

When the transmitter signal is no longer sensed by the receiver, the Time Out process begins. The Time Out period is set to 450 msec at the factory. If the receiver does not establish contact with the transmitter within that time period, it goes into the Safe Mode. In Safe Mode, the receiver shuts off activation power to the output relays and activates the E-stop function. To restart the system, be sure the transmitter signal is active and sensed by the receiver. Then press the Start/Horn pushbutton.

## SAFETY

### SAFETY ALERTS



Look for this symbol to point out important safety precautions. They mean:

**Attention!**

**Personal Safety Is Involved!**

**Become Alert!**

**Obey The Message!**

The safety alert symbol is used in decals on the unit and with proper operation procedures in this manual. Understand the safety message. It contains important information about personal safety on or near the unit.



**DANGER: IMMINENTLY HAZARDOUS SITUATION!** If not avoided, WILL RESULT in death or serious injury.



**WARNING: POTENTIALLY HAZARDOUS SITUATION!** If not avoided, COULD RESULT in death or serious injury.



**CAUTION: POTENTIALLY HAZARDOUS SITUATION!** If not avoided, MAY RESULT in minor or moderate injury. It may also be used to alert against unsafe practices.

### NOTATIONS

**NOTE:** General reference information for proper operation and maintenance practices.

**IMPORTANT:** Specific procedures or information required to prevent damage to unit or equipment.

### PRACTICES AND LAWS

Practice usual and customary safe working precautions, for the benefit of yourself and others. Understand and follow all safety messages. Be alert to unsafe conditions and the possibility of minor, moderate, or serious injury or death. Learn applicable rules and laws in your area.

### REQUIRED OPERATOR TRAINING

Original purchaser of this unit was instructed by the seller on safe and proper operation. If unit is to be used by someone other than original purchaser; loaned, rented or sold, ALWAYS provide this manual and any needed safety training before operation.

ALWAYS review the operators manual of any machine to be controlled by radio remote control.

### SAFETY RULES

This radio remote control system is equipped with electronic and mechanical safety features. Processing of control signals transmitted from other transmitters is not possible, since transmission coding is unique to each system.

### POSSIBLE SOURCES OF DANGER

This system makes remote control via radio signals possible. However, the transmission of control commands can take place around obstacles and out of the operator's direct sight. To prevent accidental start-up and possible injury or damage:

1. Always engage the E-stop button and switch "OFF" the transmitter when it is not in use. Remove the key if the unit is placed any distance away from the operator.
2. Disconnect the power supply before any assembly, maintenance or repair work is done.
3. Never remove or alter any of the safety features of this system.

### OPERATION AND WORK AREA SAFETY

The work area must be free from obstacles, debris or other tripping hazards. Avoid uneven work areas and any rough terrain. Always be sure of your footing.

Be aware of overhead obstacles that may interfere with machine operation.

### PROTECTIVE FEATURES

These safety features help protect the operator, as well as others within the work area. The machine functions can be stopped by pushing the emergency stop button on the transmitter (EMERGENCY STOP).

**NOTE:** The E-stop command is initiated within approximately 0.5 seconds (450 ms) after the switch is turned to the "OFF" position.



**WARNING:** Accidental start-up can cause serious injury or death. NEVER remove or modify any safety feature.

### TO STOP IN AN EMERGENCY

1. Press the red "EMERGENCY STOP" pushbutton.
2. Turn the key to "OFF".

3. Wait for all moving machine parts to stop.
4. Refer to machine's operator manual for further instructions.

### MAINTENANCE AND STORAGE

Always shut off power to the machine and the radio remote control system before any assembly, maintenance or repair.

## RECEIVER INSTALLATION

### RECEIVER COMPONENTS



**WARNING:** FAILURE TO FOLLOW INSTRUCTIONS could result in personal injury and/or damage to equipment. Read and understand the safety instructions in all manuals provided.

DO NOT touch any circuit components on the circuit board while the main AC or DC power is on.

DO NOT run control wires with power wires.

Surge suppressors must be used with all magnetic contactors that are controlled by the radio remote control system.

The receiver accepts commands from the remote control transmitter and interfaces with the crane controls to activate crane functions. Receiver components are shown below. Mounting dimensions are shown later in this section.

- |  |  |
|--|--|
| 1. Receiver enclosure                                | 14. Receiver status diagnostic LED's (1 of 4)                          |
| 2. Receiver cover                                    | 15. Microprocessor clock control solder jumper (J11)                   |
| 3. E-stop input fuse (F2 - 6,3A slow blow)           | 16. Latching/momentary relay output jumper block (1 of 4)              |
| 4. AC common input fuse (F1 - 315mA slow blow)       | 17. Motion relay LED (1 of 14)   |
| 5. E-stop output relay                               | 18. Motion output relay (1 of 14)                                      |
| 6. E-stop LED  | 19. Attachment board connection  |
| 7. Output mapping, DK access and power access points | 20. Attachment board safety relay activation set jumper block (1 of 3) |
| 8. Receiver setting jumper block (J1-J5)             | 21. Cable gland orifice (1 of 4)                                       |
| 9. Receiver setting solder jumpers (J6-J8)           | 22. Control output terminal block (1 of 3)                             |
| 10. RF module w/internal antenna                     | 23. Ground post  |
| 11. ADMO address module                              | 24. Receiver printed circuit board (PCB)                               |
| 12. RF module input connection                       | 25. Input power terminal block   |
| 13. Additional DK access and power access points     |  |

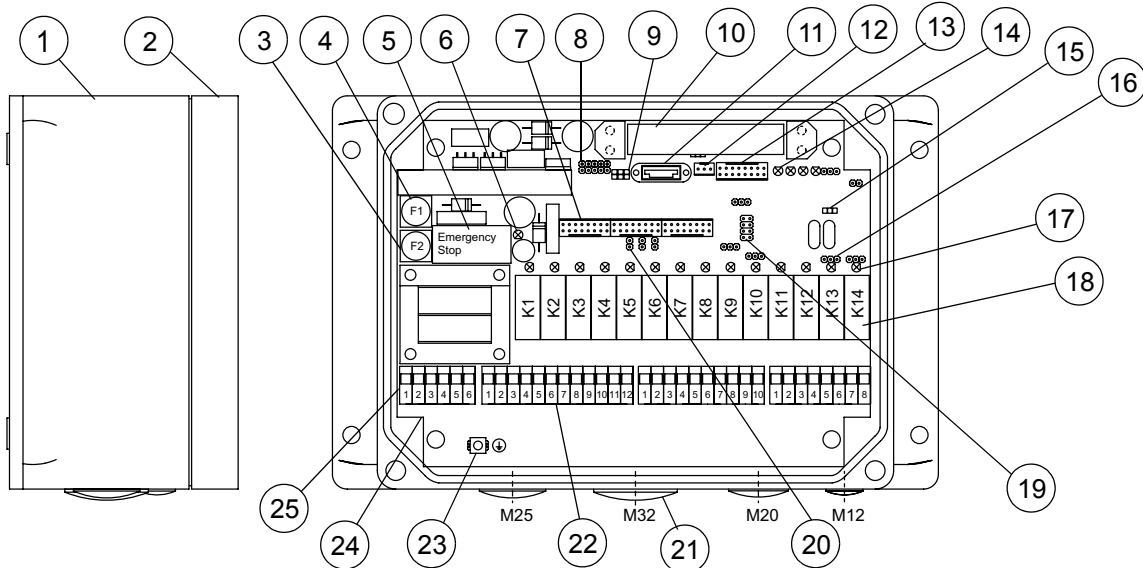

## RECEIVER LOCATION

Select a position for the receiver that provides protection from violent impact from debris or thrown materials and is easily accessible. The receiver housing is rated IP65 and can withstand direct water jet spray and is protected against penetration of dust. There are different sizes and types of receiver housings. All receivers must be free from metal obstructions on at least 3 sides with the antenna pointing straight up.

- Depending on customer specification, the receiver can be operated with AC, DC or both.
- Receiver must be protected from corrosive gases or liquids
- Receiver must be protected from ambient temperatures outside the range of  $-18^{\circ}$  to  $158^{\circ}$  F ( $-25^{\circ}$  to  $+75^{\circ}$  C)

## Receiver Production Number

Locate the Hetronic Production number decal on the receiver housing. This number is required when Hetronic is called for any service or parts information. Be sure the decal is easily accessible when the receiver is mounted to the equipment. Please make a note of the Production and System numbers in the boxes provided in the Introduction Section of this manual.

## MOUNTING THE RECEIVER

The receiver should be mounted in an easily accessible position.



**WARNING:** The connection of the radio remote control receiver to the electrical system of the machine must only be done by a competent technician.

**IMPORTANT:** Refer to the document case (located on the inside of the receiver cover) in the receiver for receiver layout instructions.

**NOTE:** The maximum allowed current for the relay contacts is 8 amps with AC. If a higher current is necessary, the appropriate relays must be installed in the electrical system of the carrying vehicle.

1. Determine the receiver position.
2. If the receiver is to be mounted inside a control panel or other enclosure, an external antenna is required.
3. Be sure there is clearance for connectors and components that need to be wired.
4. Drill holes into the mounting surface according to the dimensions shown.
5. Insert the mounting screws through the holes in the receiver housing and tighten into the mounting surface.
6. Please refer to the appropriate illustration for mounting dimensions. Contact Hetronic for more information or if you have questions.

7. Lay out the wire runs. Use #16 AWG (size 1.5 mm<sup>2</sup> metric) minimum for power wiring.
8. If the receiver includes an attached antenna, mount the receiver so that the antenna points straight up. The area around the antenna should be free of obstructions, especially metal.

The receiver wiring is critical for proper system operation. Make all connections with good quality contacts or solder joints to ensure proper electrical contact.

Supply voltage and ground wiring are crucial and must be connected to reliable connecting circuitry. Do not use a chassis ground for this equipment. The ground wire must be connected directly to the crane/machine's ground.

The output control signals to controls should be routed separately from any wiring that could produce transient voltage interference. Interference or "induced voltage spikes" could cause erratic performance of the controls.

## Receiver Mounting Dimensions

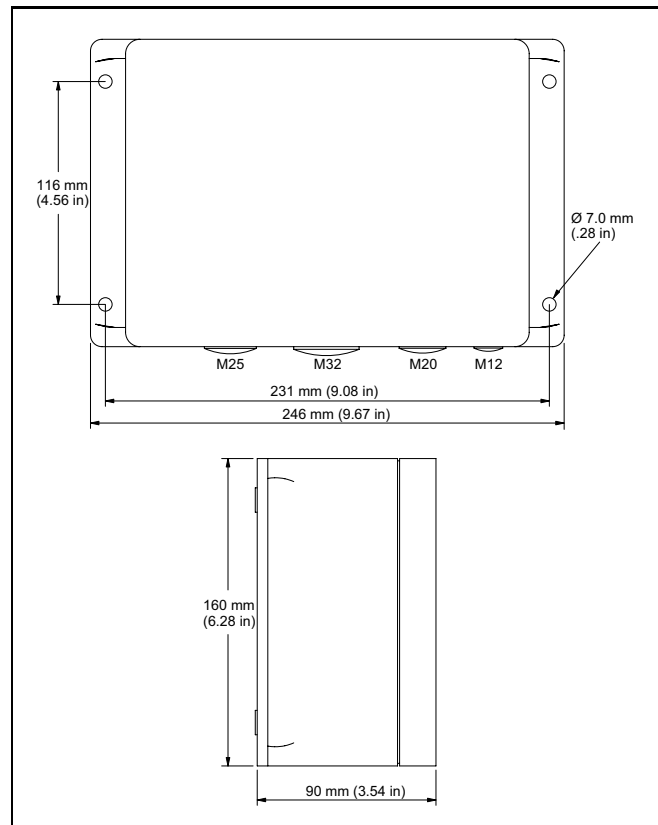

## Standard External Antenna Installation

If the receiver must be located inside a control panel or other enclosure, an external car antenna may be required. Mount the antenna onto a metal surface with the same ground as the receiver circuit board. Remove any burrs from the antenna mounting hole and scrape away any paint which may insulate the antenna base from making positive contact.

**NOTE:** Improper installation of the antenna will cause intermittent signal loss.

1. Drill a hole 14 mm (.56 in.) dia. through the control panel or enclosure at the external car antenna location.
2. Insert the connector base through the hole with the antenna on the outside. Seat the base firmly against the enclosure surface.
3. Assemble the antenna as shown below.

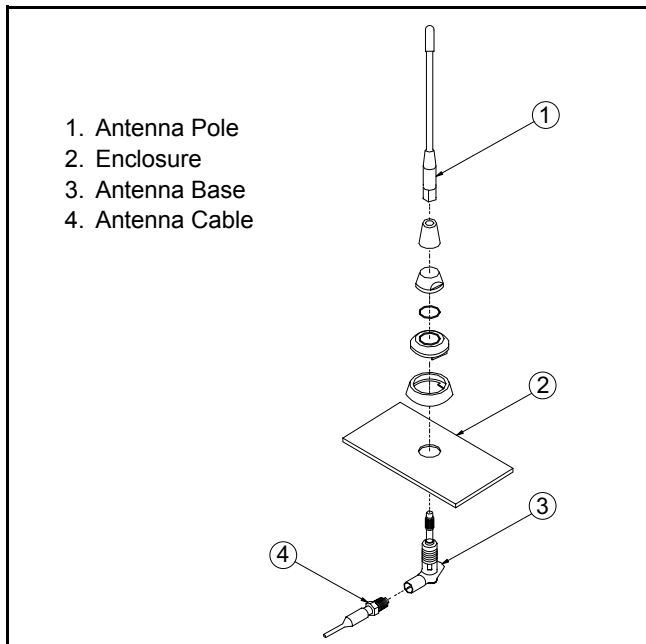

4. Screw the antenna pole onto the antenna base.
5. Remove the Miniflex antenna from the receiver housing by unscrewing it from the antenna base.
6. Connect the external antenna cable to the antenna base on the receiver housing.
7. Bundle any excess antenna cable and secure with tie wraps or equivalent.

**IMPORTANT:** DO NOT run the antenna cable with power or control wiring. Intermittent signal loss will result.

## GainFlex Antenna Installation

Your application may require the use of a GainFlex antenna. The GainFlex antenna can extend the range of the radio remote control system up to 300 meters (1000 ft.). It can also be used where a standard antenna is difficult to mount. If you are not sure which antenna is suitable for your application, please contact Hetric or your dealer.

When using a GainFlex antenna, there must be no metal or conductive materials within 2 meters (6 feet) of the antenna. This material will interfere with the transmitter signal and cause intermittent signal loss. For the best reception, the antenna should point upward.

**NOTE:** Improper installation of the antenna can cause intermittent signal loss.

1. Secure the GainFlex antenna base to a mounting surface with the tie wraps included. Mount the antenna vertically with the base pointed upward.

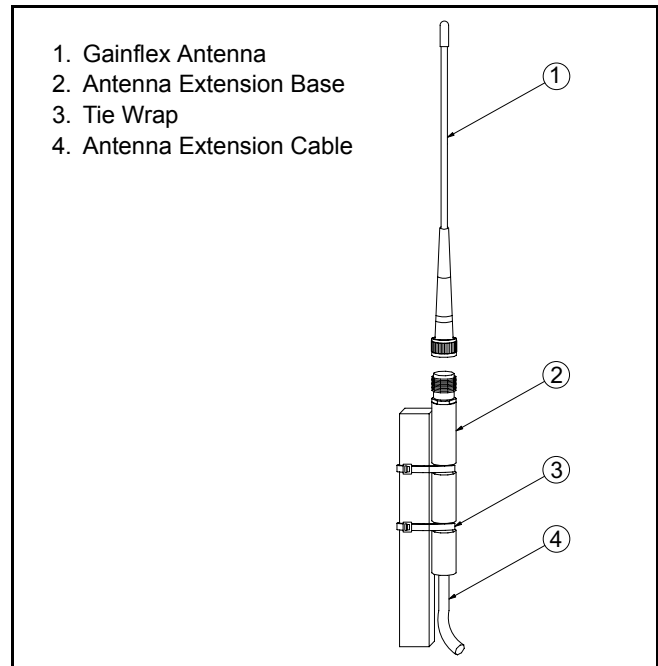

2. Screw the GainFlex antenna pole onto the base.
3. Unscrew the Miniflex antenna from the receiver housing.
4. Connect the GainFlex antenna cable connector to the existing antenna base on the receiver housing.
5. Bundle any excess antenna cable and secure with tie wraps or equivalent.

**IMPORTANT:** DO NOT run the antenna cable with power or control wiring. Intermittent signal loss will result.

## CONNECT ELECTRICAL WIRING

Connect all remaining wires (power supply, E-stop start/horn, etc.) according to the wiring diagram of the crane/machine and the radio remote control. The receiver outputs are shown in the following illustrations.



# Ergo V1 System Receiver Outputs

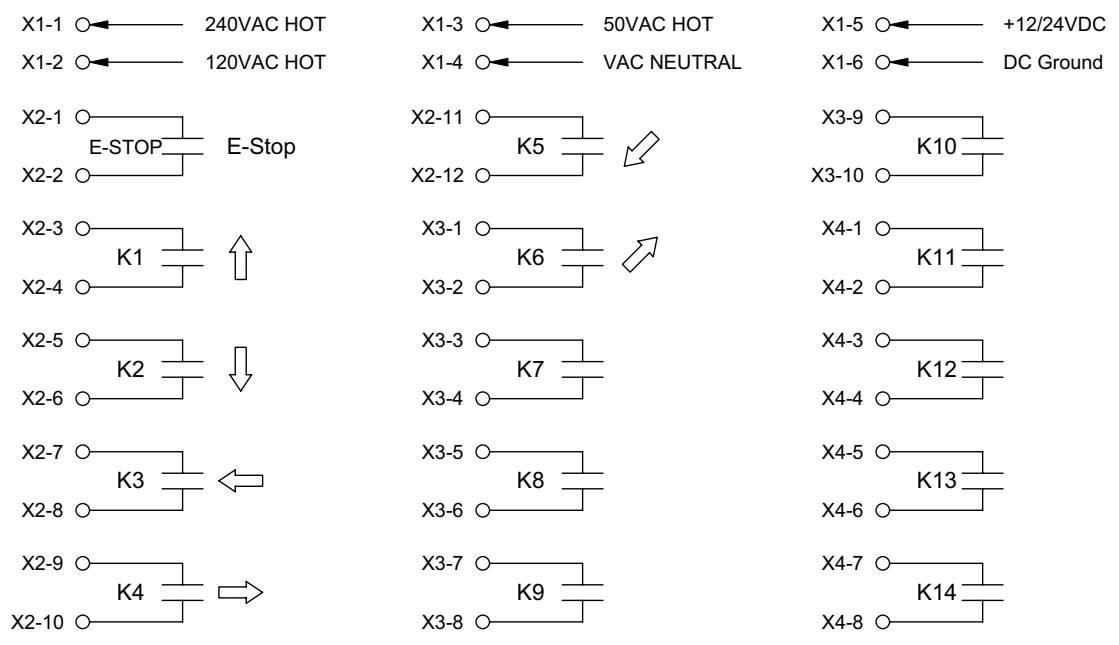
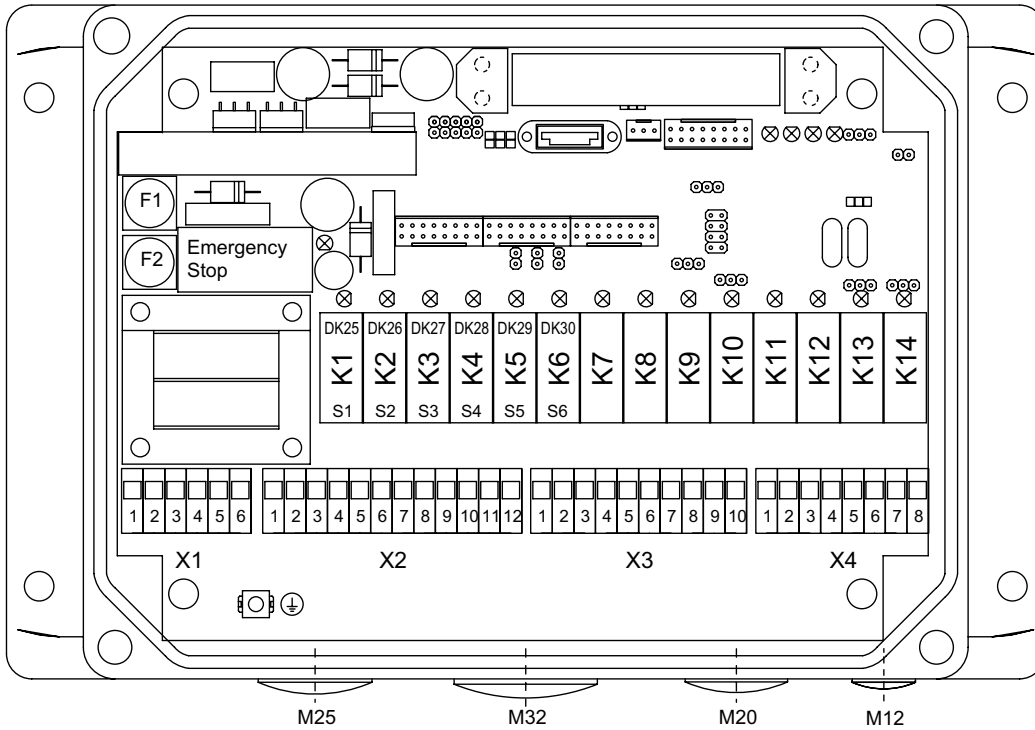

# Ergo V2 System Receiver Outputs

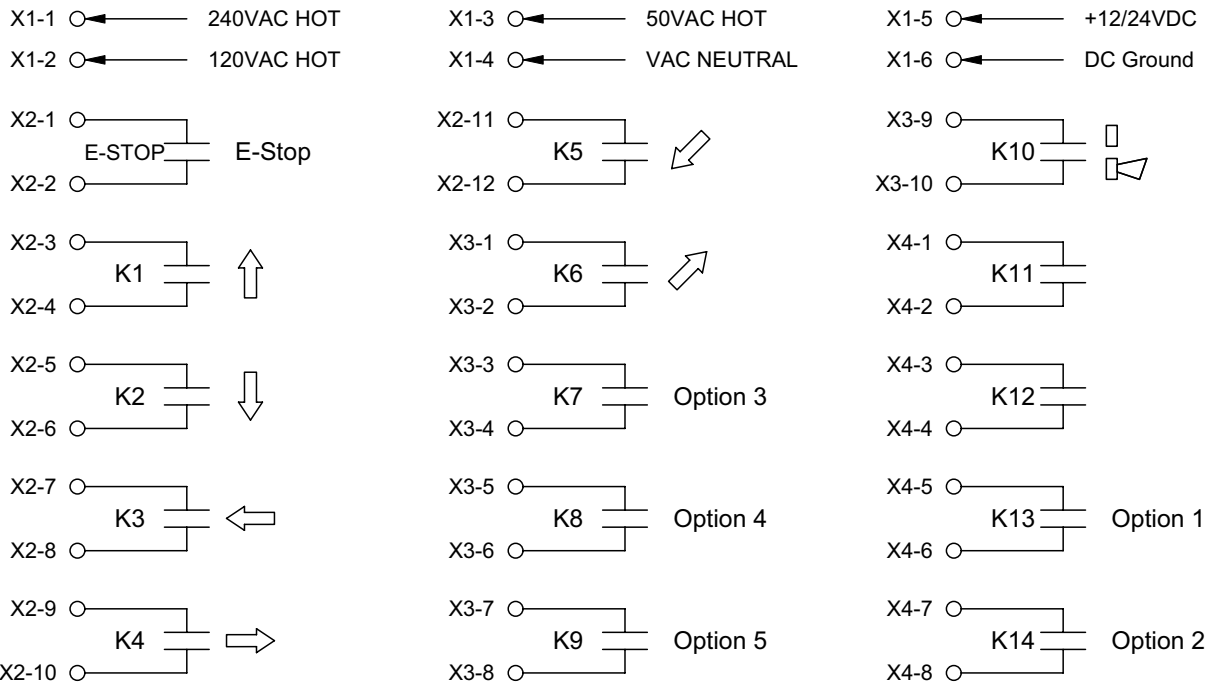
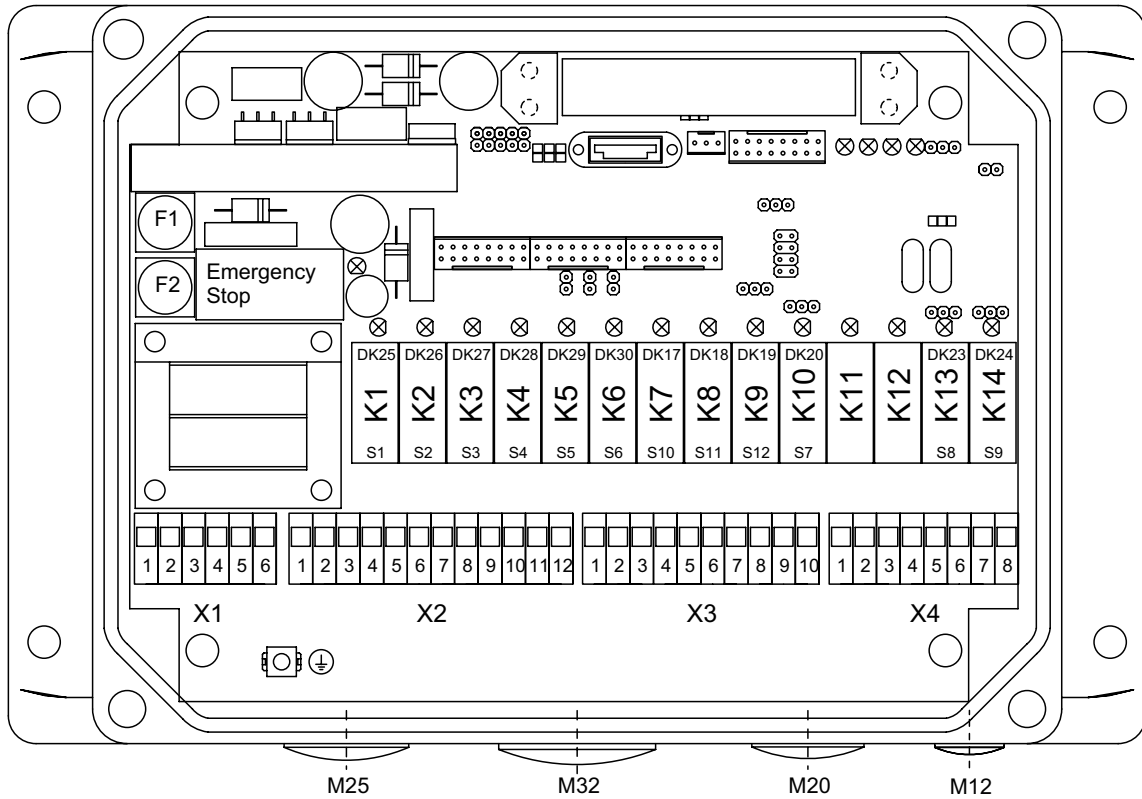

# Ergo V4 System Receiver Outputs

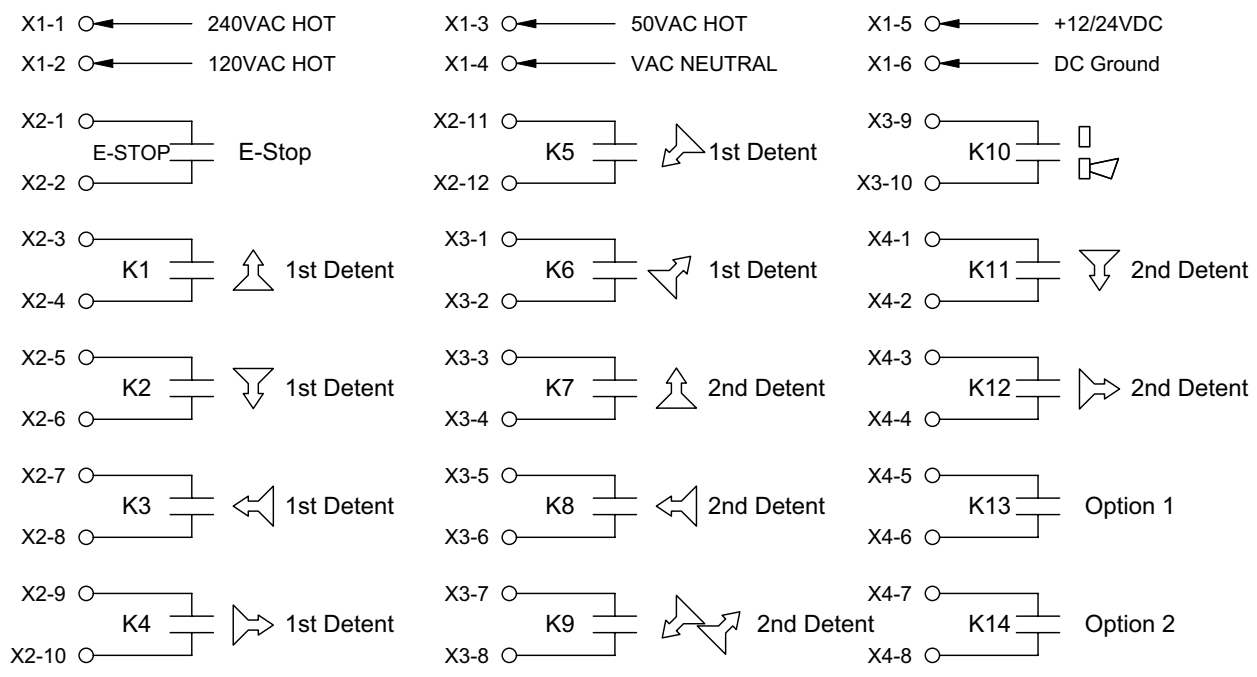
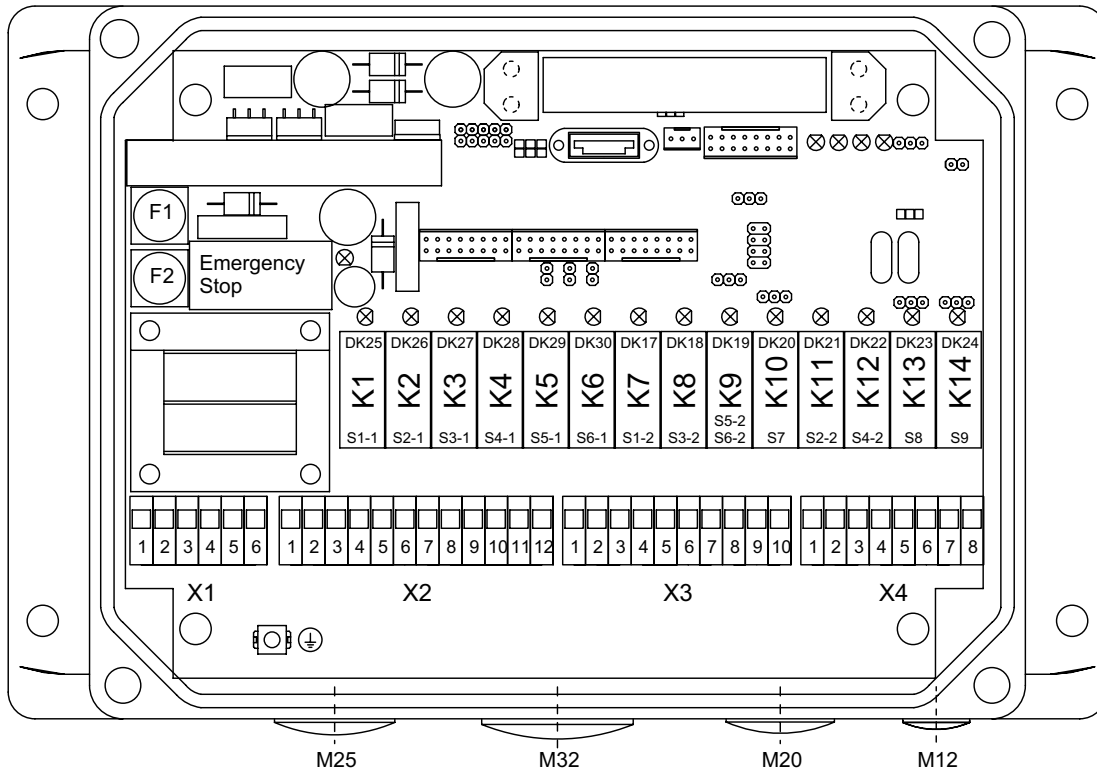

# Ergo V5 System Receiver Outputs

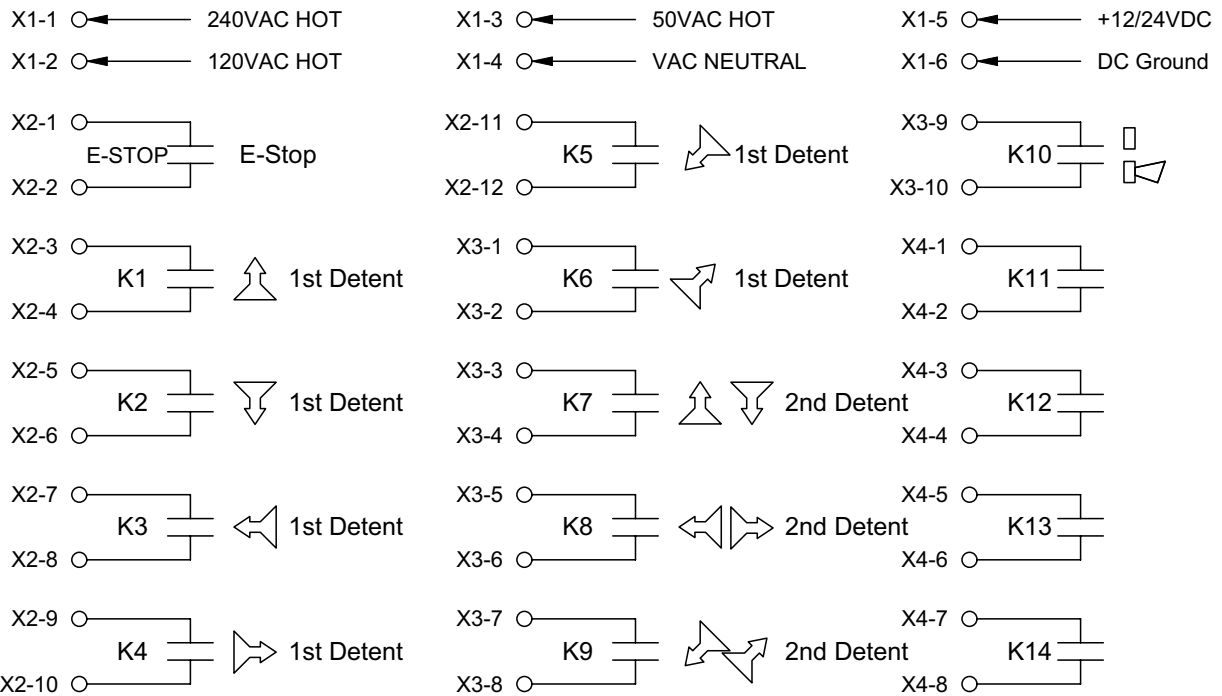
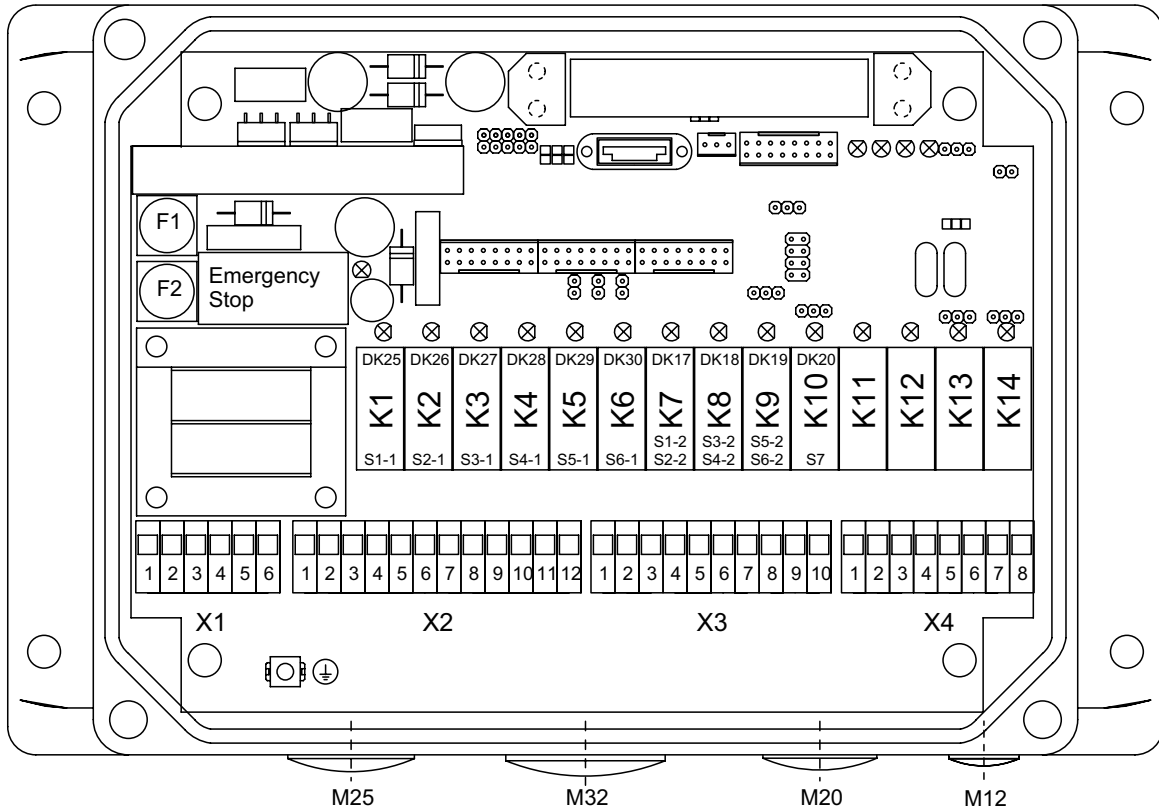

# Ergo V7 System Receiver Outputs

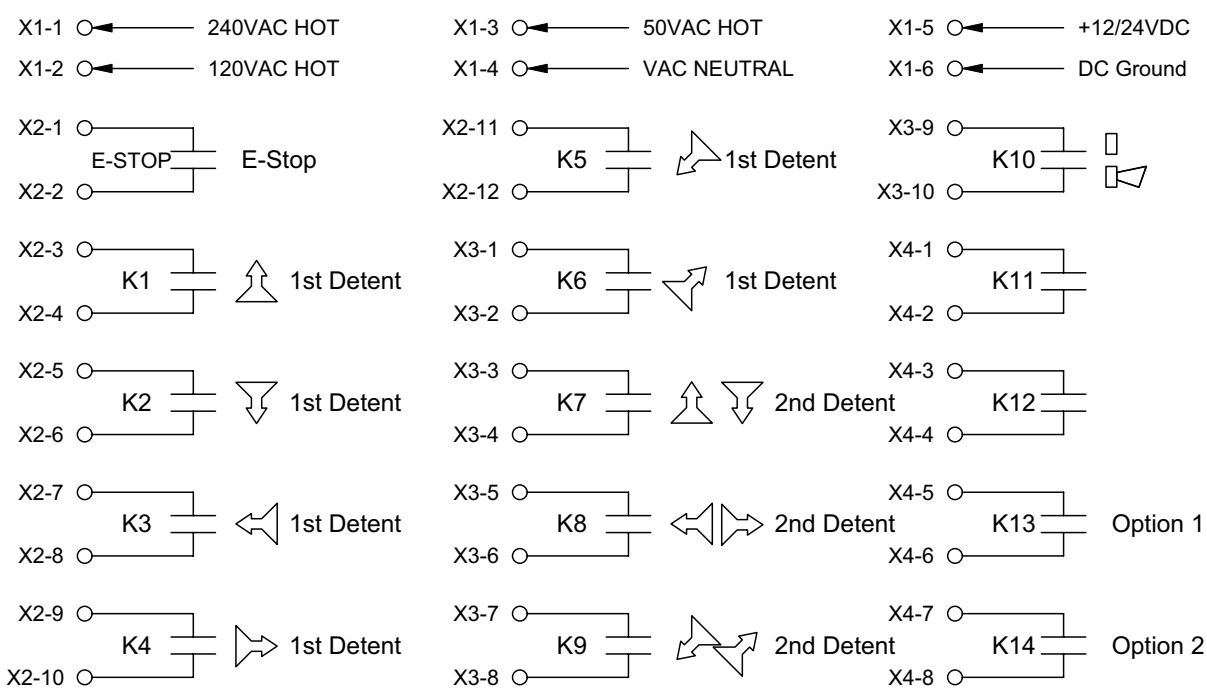
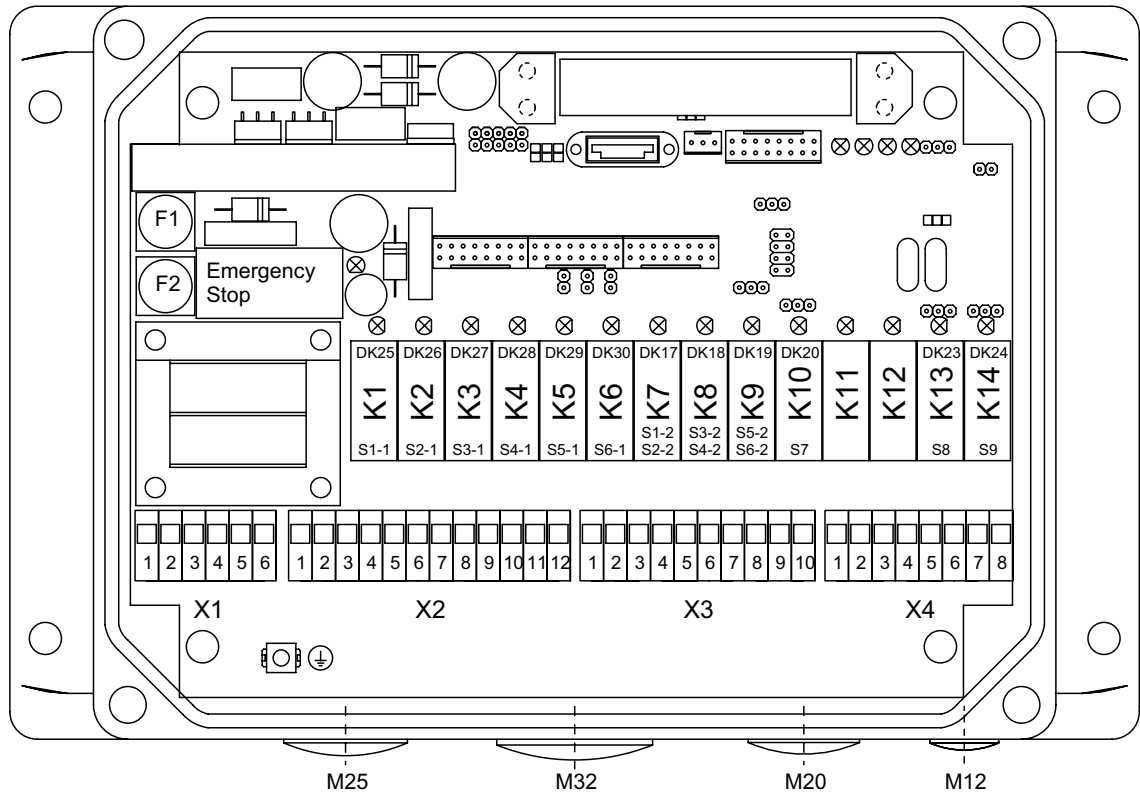

# Ergo V8 System Receiver Outputs

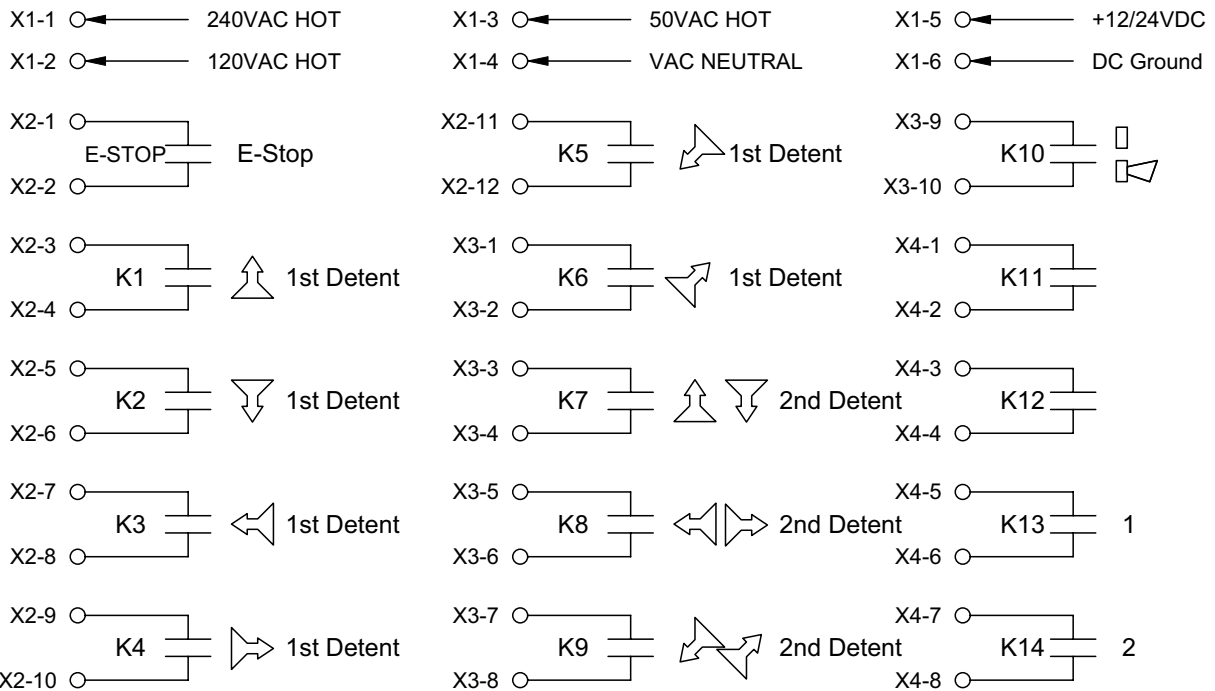
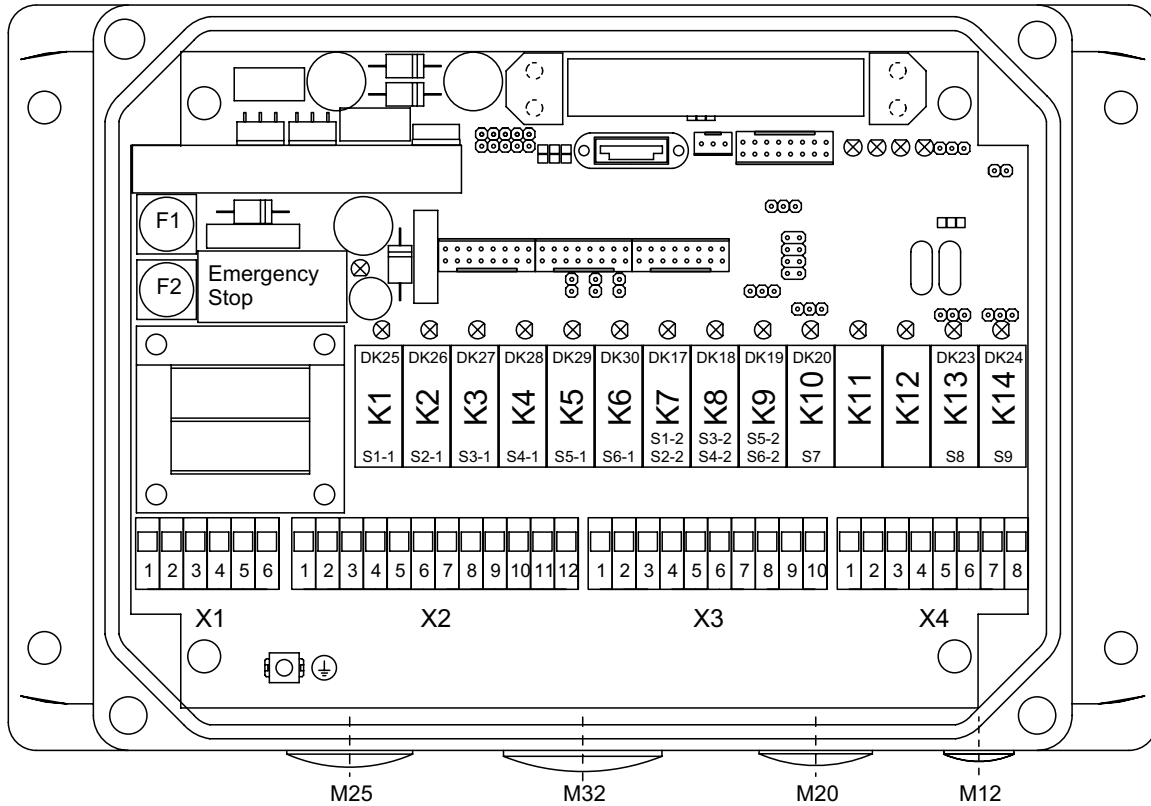

**Typical Overhead Traveling Crane Supply,  
Start, & E-Stop Wiring**

**NOTE:** Material Handling Only.

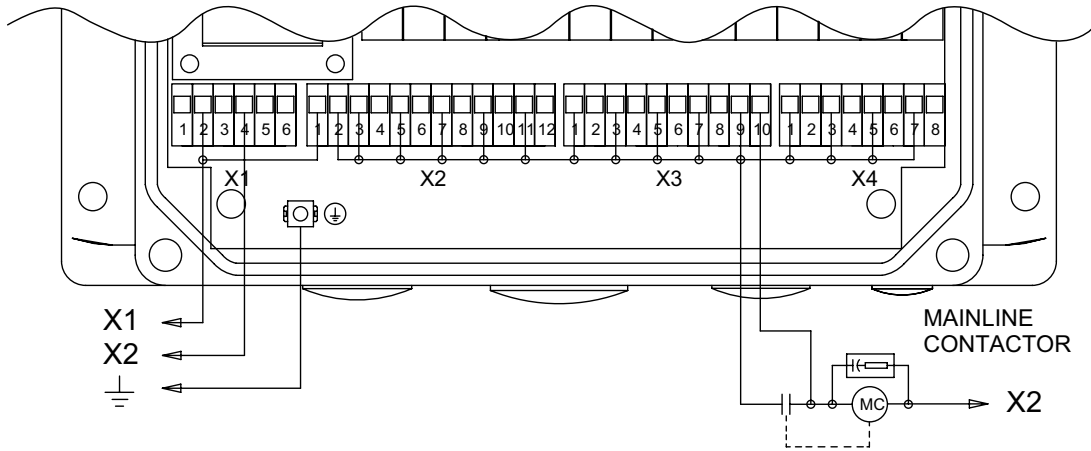

**Typical Overhead Traveling Start Circuit with  
Horn**

**NOTE:** Material Handling Only.

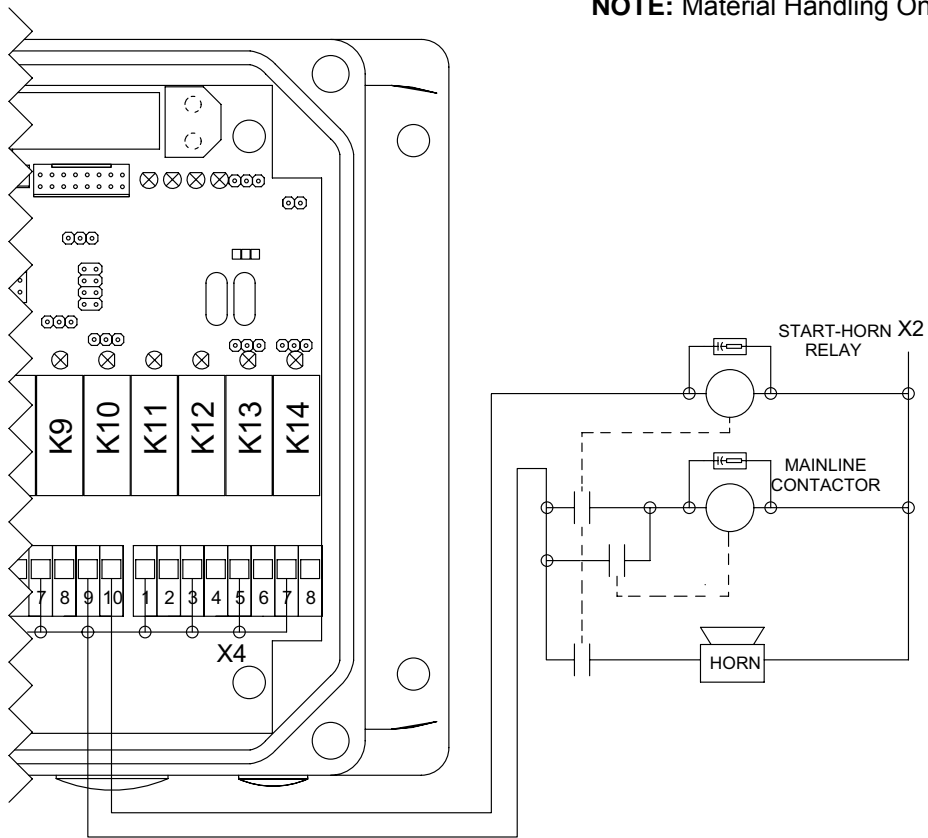

# ERGO TRANSMITTERS

Each Hetronic radio remote control system is delivered with 3 AA batteries and a battery adapter case. The Ergo is designed to use typical AA batteries that can be purchased separately. An optional battery charger with rechargeable batteries is available from Hetronic. Different charger versions can use an 110/120 VAC, 12 VDC direct wired, or 12 VDC with cigarette lighter connection for the power source. See "Maintenance Section" of this manual. Contact Hetronic or your Dealer for more information.

Please note that the actual configuration of each radio may be designed specifically per customer requirements and can vary from the illustrations shown in this manual. Refer to the technical documentation provided with each system for the actual design, layout and components.



**WARNING:** The transmitter coder settings are set at the factory and should be changed by Hetronic service personnel only. Incorrectly changing the settings of the transmitter coder board could result in damage to equipment, serious injury or death.

## FREQUENCY AND ADDRESS SETTINGS

Each Hetronic radio remote control system contains a radio frequency (RF) unit. Each system consists of a transmitter RF unit and a receiver RF unit.



**CAUTION: AVOID INJURY OR DAMAGE -** Operating the transmitter without its antenna could destroy the final stage of the RF module. DO NOT attempt to change the Hetronic pre-set frequency or the 20-bit address. Personal injury and property damage could result from transmission interference and may void the warranty.

The address settings are pre-set at the factory in the ADMO module. However, if the transmitter coder board, the base board, or if the entire transmitter or receiver are replaced, the ADMO address must match the system.

**IMPORTANT:** If the ADMO settings of the transmitter and receiver do not match, the system will not function.

## ERGO V1 TRANSMITTER

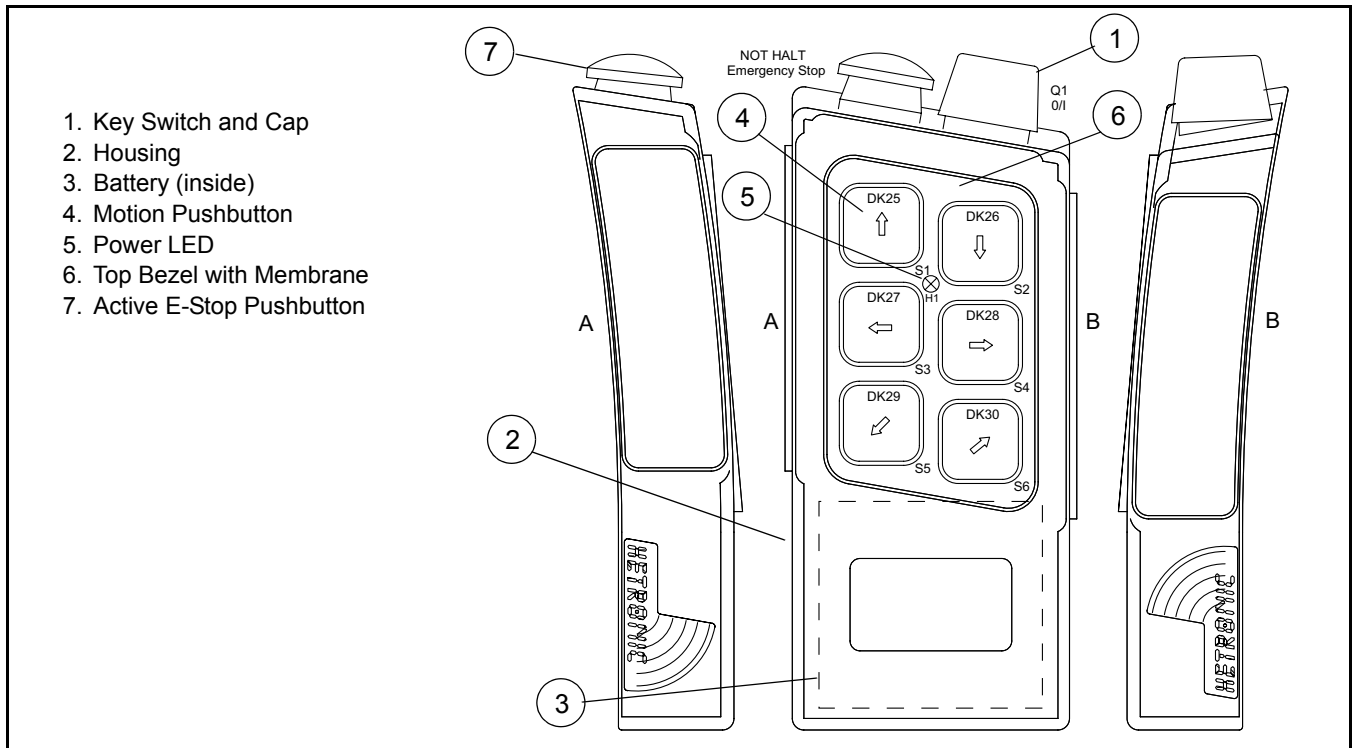



## ERGO V2 TRANSMITTER

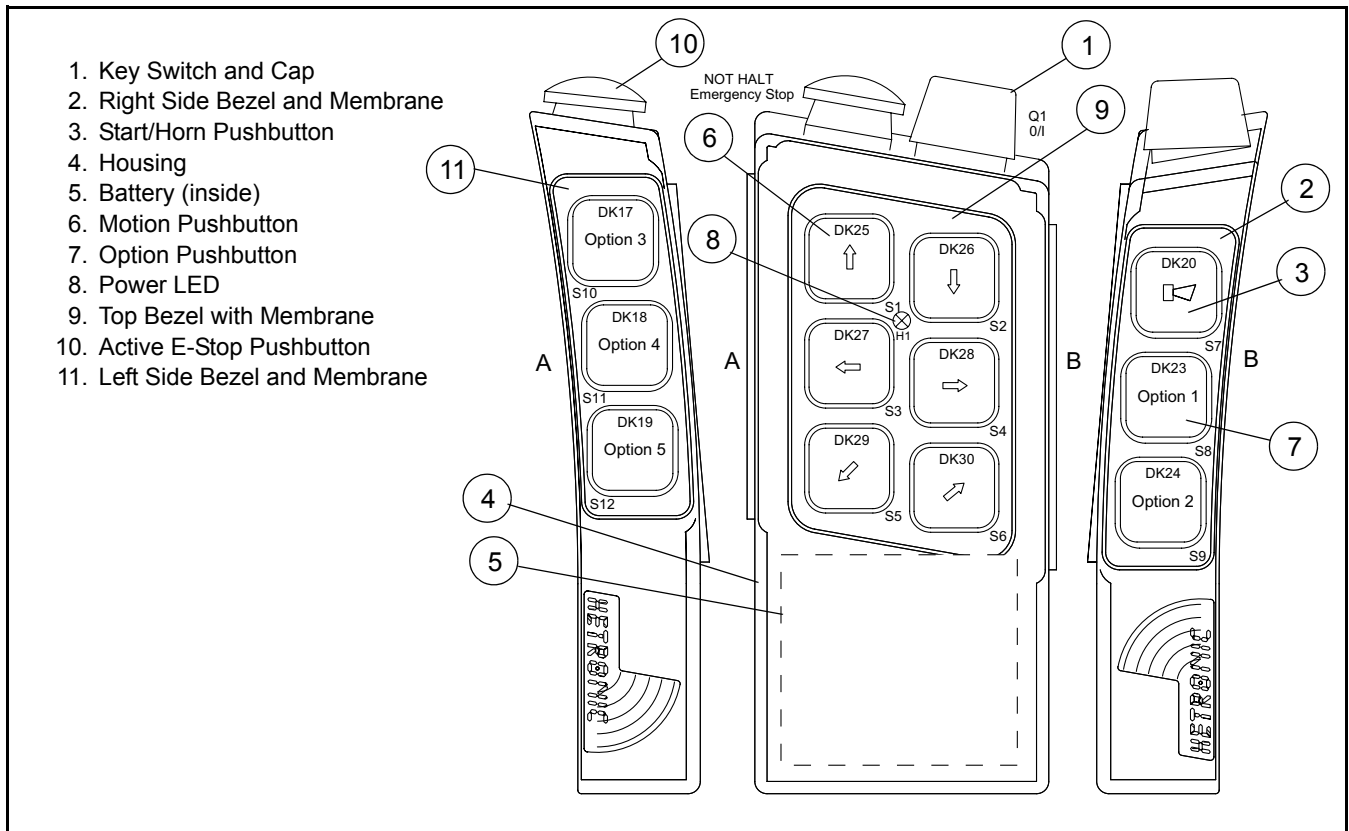

## ERGO V4 TRANSMITTER

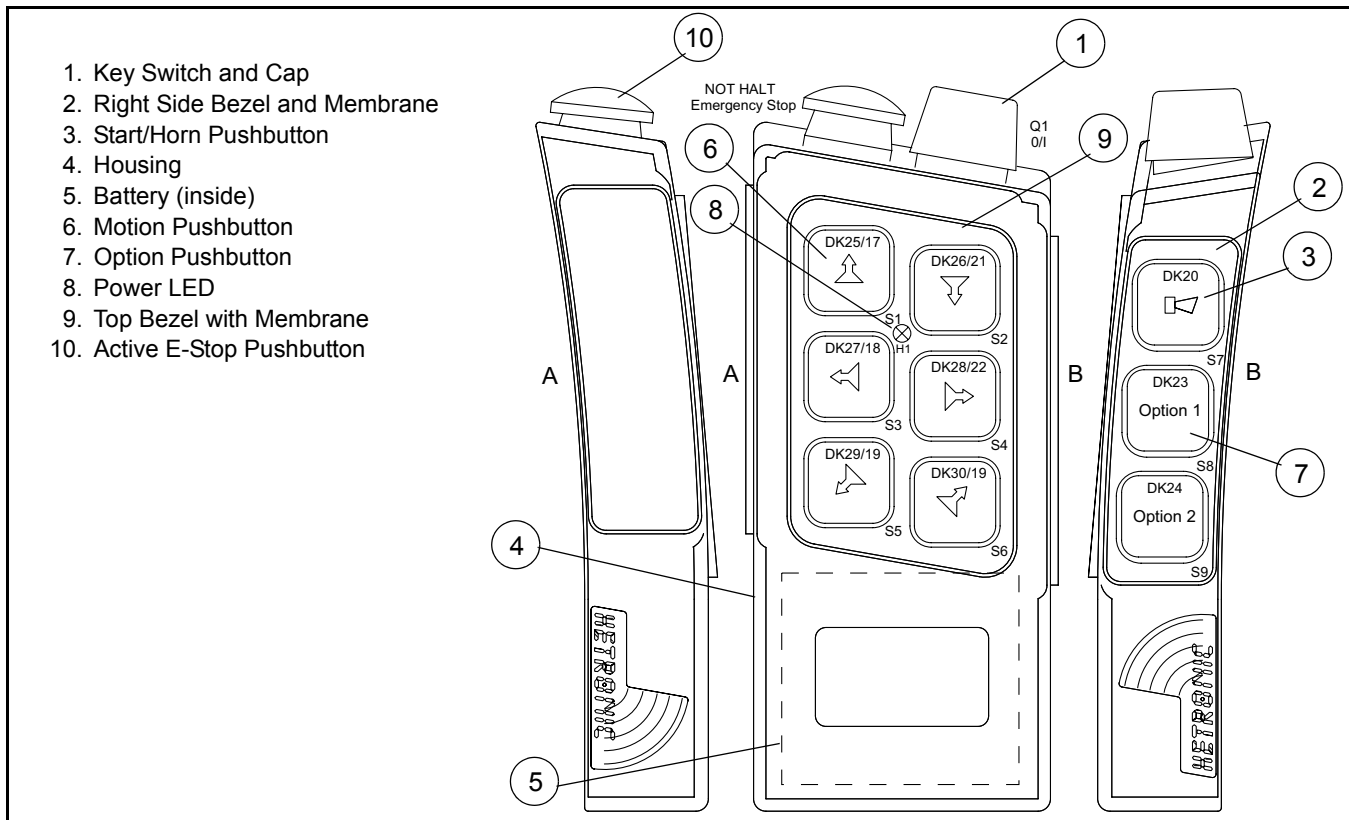

## ERGO V5 TRANSMITTER

1. Key Switch and Cap
2. Right Side Bezel and Membrane
3. Start/Horn Pushbutton
4. Housing
5. Battery (inside)
6. Motion Pushbutton
7. Power LED
8. Top Bezel with Membrane
9. Active E-Stop Pushbutton

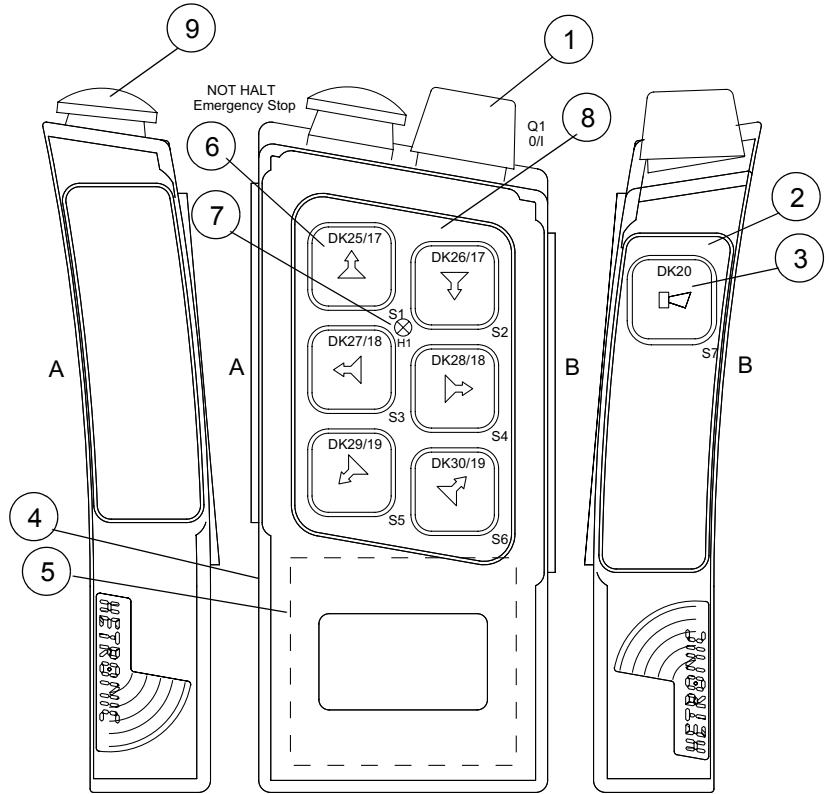

## ERGO V7 TRANSMITTER

1. Key Switch and Cap
2. Right Side Bezel and Membrane
3. Start/Horn Pushbutton
4. Housing
5. Battery (inside)
6. Motion Pushbutton
7. Slide Selector
8. Power LED
9. Top Bezel with Membrane
10. Active E-Stop Pushbutton

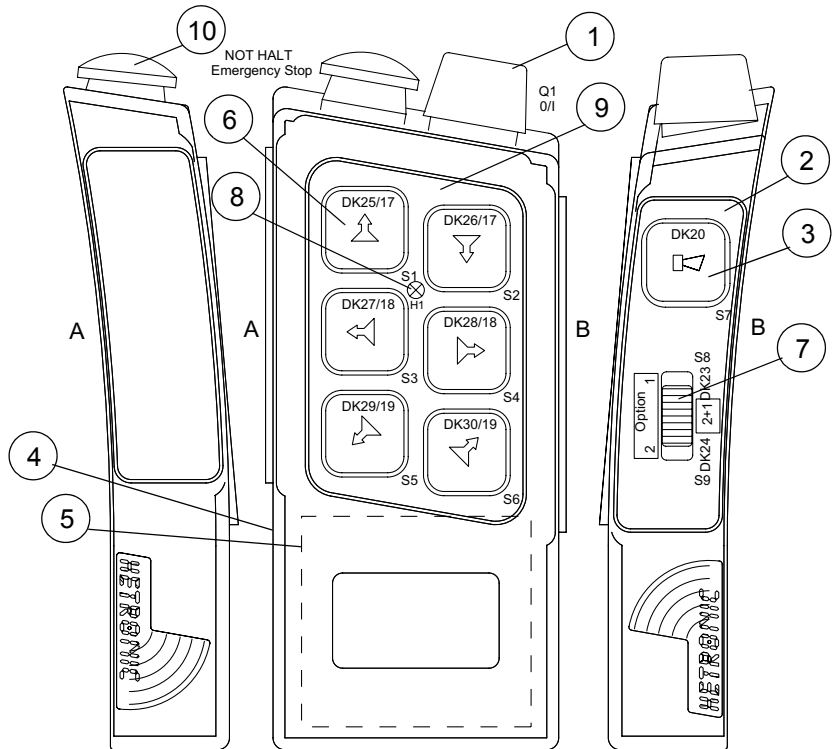

# ERGO V8 TRANSMITTER

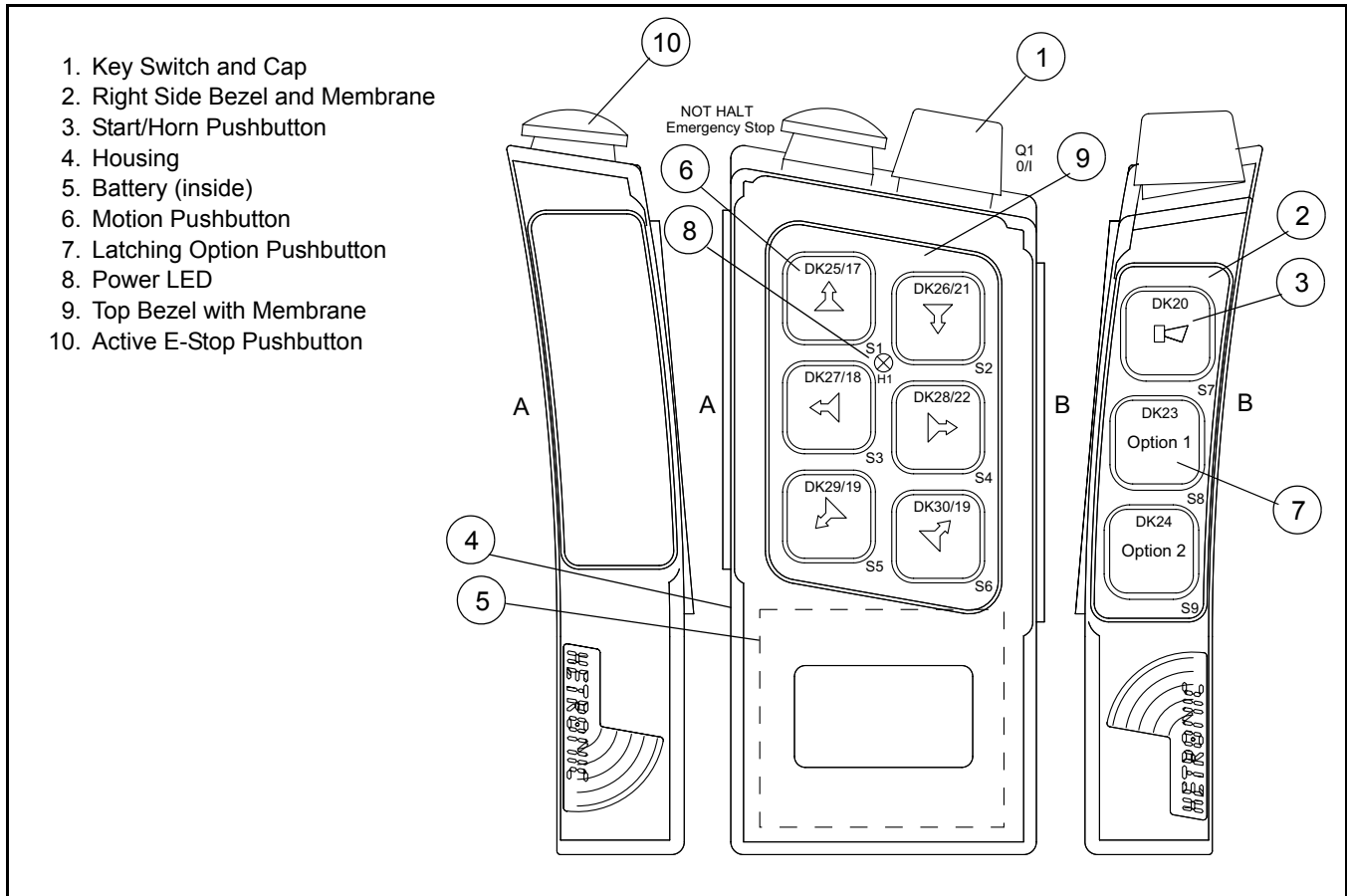

## TRANSMITTER SETUP

This section describes the steps to properly label the transmitter for operation.

### Placing the Pushbutton Labels

If your Ergo transmitter came with pushbutton labels, insert them into the transmitter as shown below.

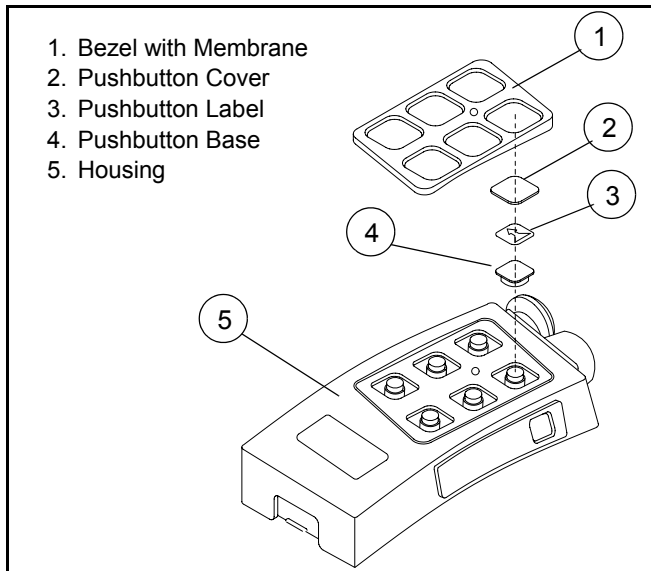

1. Remove the pushbutton cover from the pushbutton base.
2. Remove the pushbutton label.
3. Place the new label into the pushbutton cover face down, so the label shows when the cover is turned right-side up.
4. Snap the pushbutton base back into the cover.
5. Repeat these steps for each label to be replaced.
6. If necessary, clean the transmitter housing with rubbing alcohol to remove any traces of dirt, oil or other debris.
7. Place the pushbuttons on the transmitter according to the layout for your application.
8. Remove the adhesive strip from the back of the membrane and carefully place it on the enclosure.
9. Press the bezel firmly into place.

**NOTE:** DO NOT use any type of glue or adhesive to secure the bezel to the transmitter housing. Incorrect adhesives can damage the transmitter and will void the warranty.

# TEST PROCEDURES



**WARNING:** FAILURE TO FOLLOW INSTRUCTIONS could result in personal injury and/or damage to equipment. Read and understand the safety instructions in all manuals provided.

Testing or service must be performed by authorized personnel only.  
There must be no load on the crane/machine.  
Clear the crane/machine operating area of obstructions.

- Be sure there are fully charged batteries or optional rechargeable battery pack in the transmitter.
- Push in the E-Stop button.
- Be sure the motion pushbuttons are in their OFF (neutral) positions.

## TEST THE SYSTEM

- Remove the cover from the receiver.
- Position yourself in front of the receiver so that all LEDs and connections are visible.

## LED Designations and Layout

Check the following list before turning the transmitter on.

1. CPU Yellow LED 1
2. Transmission Green LED 2
3. E-stop Fault Red LED 3
4. Telegram Type Red LED 4
5. E-stop Relay Activated Red LED 5
6. Output Relays K1 - K14 Activated Red LEDs 6 - 19

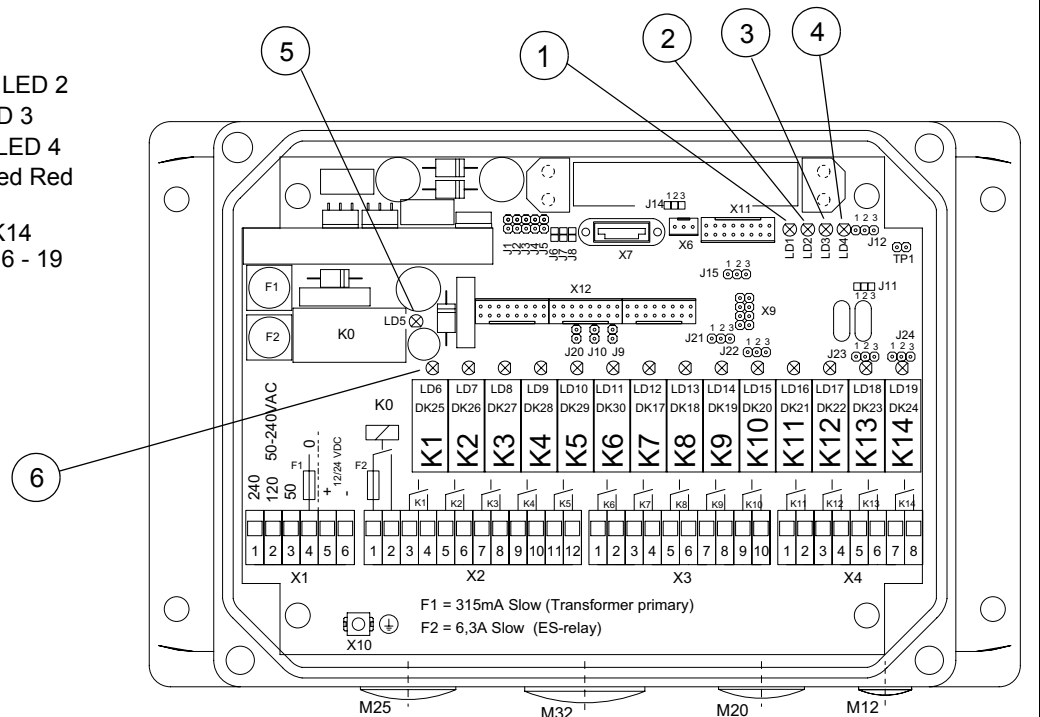

1. Be sure that all safety measures required by the equipment manufacturer have been followed.
2. Turn on power to the receiver. The CPU Standby LED (1) should flash yellow to indicate the microprocessor is working properly.

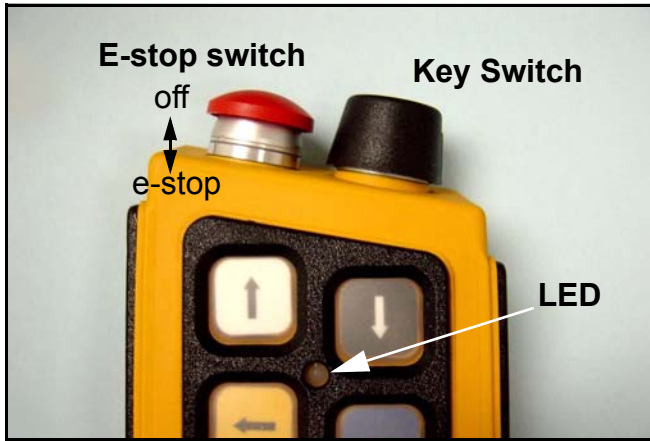

3. Place the key switch on the transmitter in the OFF position and the E-Stop pushbutton in the OFF position (i.e. pull it out).
4. Place the battery adaptor pack with fresh batteries or a fully charged optional rechargeable battery pack into the battery compartment located at the bottom of the transmitter.
5. Turn the key switch to the ON position. The LED on the transmitter flashes RED to indicate the diagnostic test in progress. The LED on the transmitter flashes GREEN to indicate successful diagnostic testing.
6. Immediately following the diagnostic test, the Receiver Transmission LED (2) should flash. This indicates that the receiver is detecting a valid signal from the transmitter.
7. Pull out the E-Stop pushbutton. The Receiver E-Stop Relay LED (5) should illuminate.
8. Push in the E-Stop pushbutton. The E-Stop Relay LED should go off.
9. Pull the E-Stop pushbutton out.

10. Press the Start/Horn pushbutton on the transmitter. The Start Relay LED should illuminate and the crane horn will sound (if wired). The main line contactor will activate at this time (depending on crane wiring).
11. Activate the motion pushbuttons to test the crane/machine functions.

**IMPORTANT:** The crane/machine functions will operate during this check. Be certain that there are no obstacles near the crane/machine.

12. Confirm that the crane/machine moves appropriately and that the correct LEDs illuminate for each crane/machine motion.
13. Activate the Option functions, if supplied, to test optional crane/machine functions.
14. Push in the E-Stop pushbutton and turn the key switch to the OFF position. The E-stop and relay output LEDs in the receiver should turn off.
15. If transmitter and receiver function properly, the system is ready for use.
16. Install the cover onto the receiver.
17. If the receiver or transmitter does not operate properly, or if the crane/machine does not react as directed, shut the entire system down and refer to the Troubleshooting Section. If necessary, contact Hetronic or your Dealer.



**WARNING:** The Receiver settings are set at the factory and should be changed by Hetronic service personnel only. Incorrectly changing the settings of the receiver could result in damage to equipment, serious injury or death.

## OPERATION



**WARNING:** FAILURE TO FOLLOW INSTRUCTIONS could result in personal injury and/or damage to equipment. Read and understand the safety instructions in all manuals provided.

### HOLDING THE TRANSMITTER

Hold the transmitter with the control panel facing you. Be sure that you are able to easily read any text and understand the operation symbols.



**WARNING:** FAILURE TO FOLLOW INSTRUCTIONS could result in personal injury and/or damage to equipment. Always hold the transmitter in the proper orientation. Holding the transmitter improperly while operating the crane/machine could result in unexpected crane/machine response.

The procedures described in the following paragraphs must be completed before the radio remote control system is activated. These checks must be performed at least once a day, before the start of any operation and at all shift changes.



**WARNING:** FAILURE TO FOLLOW INSTRUCTIONS could result in personal injury and/or damage to equipment. Test the "E-STOP" function as described in the crane/machine manufacturer's operator manual before beginning any operation.

## VISUAL CHECK

Always check the transmitter for any physical damage before any operation.

- Check equipment for wear or damage.
- Check rubber cuffs and pushbutton caps for wear or damage.

**IMPORTANT:** Never operate a transmitter with worn or damaged parts. Replace immediately with only Hetronic parts. Contact Hetronic or your Dealer.

## START-UP PROCEDURE

1. Be sure that all safety measures required by the equipment manufacturer have been followed.
2. Turn on power to the receiver.
3. Place the key switch on the transmitter in the OFF position and the E-Stop pushbutton in the OFF position (i.e. pull it out).
4. Place the battery adaptor pack with fresh batteries or a fully charged optional rechargeable battery pack into the battery compartment located at the bottom of the transmitter.
5. Turn the key switch to the ON position.
6. The LED on the transmitter will begin to flash red.
7. After approx. 2 seconds the LED starts to flash green.
8. Press the Start/Horn pushbutton
9. The system is now ready to use.

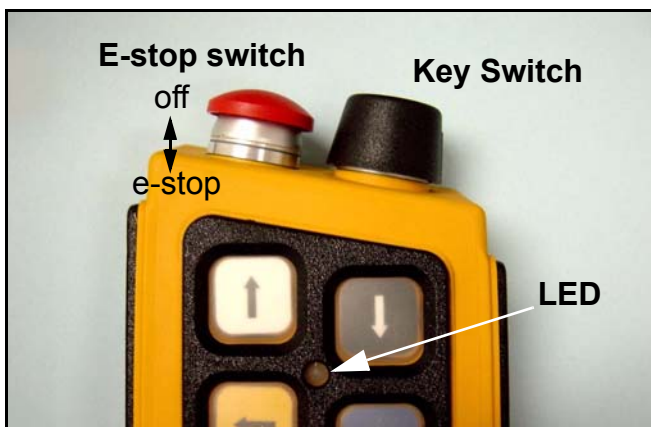

**IMPORTANT:** To avoid accidental start-up, always engage the E-stop pushbutton and switch the transmitter "OFF" when not in use. When the transmitter is not attached to the operator, the key switch should be removed and stored in a secure place.



**WARNING:** TO AVOID SERIOUS INJURY OR DEATH. Switch the crane/machine "OFF" if there is a fault or any problems with the safety check. Contact Hetronic or your dealer immediately to repair the system. NEVER operate the crane/machine when the "EMERGENCY STOP" function does not operate properly.

Improper operation, maintenance or adjustment may cause serious injury or damage to equipment and may void the warranty.

## TO STOP IN AN EMERGENCY

1. Press the red "EMERGENCY STOP" pushbutton.
2. Turn the key to "OFF".
3. Wait for all moving crane/machine parts to stop.
4. Refer to crane/machine's operator manual for further instructions.

## SAFE MODE

When the transmitter battery power is nearly exhausted, the system automatically goes into Safe Mode. The transmitter LED will flash red to indicate a low battery. At the end of the 30 seconds, the transmitter sends the E-Stop signal and all crane/machine motion commands are stopped.

To restart the system, fully charged batteries must be inserted into the transmitter. Proceed with startup instructions. Always have fully charged batteries available to continue operation of radio remote control.

# MAINTENANCE

## CHANGING THE BATTERY

The transmitter LED flashes red when the battery is nearly discharged. When the transmitter signals, the battery must be changed immediately.

Position the crane/machine into a safe place or safe condition within 30 seconds after hearing the signal.



**WARNING:** The transmitter will switch to the EMERGENCY STOP condition after 30 seconds.

## Changing Battery Adaptor with Disposable Batteries

1. Remove the spent disposable batteries from the battery adaptor pack, and dispose of properly.
2. Insert three fresh batteries into the battery adaptor pack as shown. Make sure to follow the polarity illustrations inside each battery compartment when inserting.

**IMPORTANT:** Use only AA 1.5V alkaline batteries or equivalent.



3. Insert the battery adaptor pack with fresh batteries into transmitter.

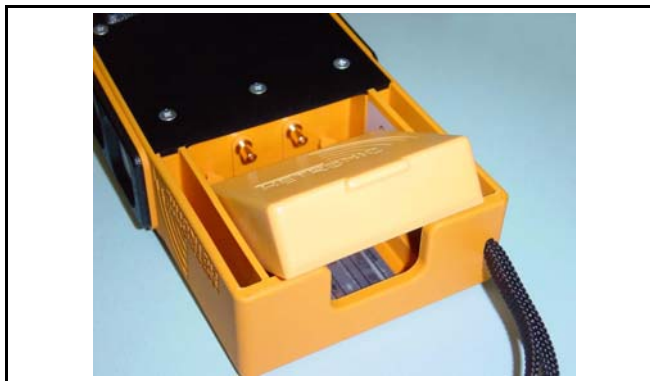

4. The Radio Remote Control is ready for operation.
5. Follow the Start-Up Procedure and safety checks to begin operation.

## Optional Rechargeable Battery Pack

1. Remove fully charged optional rechargeable battery pack from the battery charger.

2. Insert the fully charged optional rechargeable battery pack into transmitter.



3. Place the spent optional rechargeable battery pack into the battery charger as shown.
4. The Radio Remote Control is ready for operation.
5. Follow the Start-Up Procedure and safety checks to begin operation.

## BATTERY DISPOSAL

**IMPORTANT:** AVOID ENVIRONMENTAL POLLUTION. Electronic equipment and components are considered to be hazardous waste. Discarded rechargeable batteries are hazardous waste and must not be disposed of with typical refuse. Contact a professional hazardous waste disposal service.



**WARNING:** EXPLOSIVE GASES AND FLYING DEBRIS can cause death or serious injury. Use only Hetronic replacement rechargeable batteries. Use of unauthorized replacement batteries could cause a battery explosion, resulting in injury or death of the operator or other people in the work area.

## OPTIONAL BATTERY CHARGING SYSTEM

### Features

- **Normal charge or Fast charge** of Hetronic standard batteries
- **Trickle charge** - After charging process is complete, battery can remain in charger without being damaged by over-charge.
- **Battery diagnostics** - Charger determines if battery is damaged.
- **Gold plated contacts** ensure clean, positive contact between battery and charger.
- **LED status lights** indicate charging process as well as battery diagnostics

### The Battery Charger

One battery charger is designed for 115/230 VAC and another charger is designed for 12/24 VDC. Both chargers function the same.

When the battery is inserted into the charger, a flashing "CHARGE" LED lights. The charge process is terminated by detecting peak battery voltage or after 5 hours and the "READY" light goes on. When the "READY" light is lit, the charger continues to "trickle" charge the battery.

**NOTE:** If the battery is bad and has an open cell, no LEDs will light up. If the battery has a shorted cell, the "CHARGE" LED will blink continuously. In either case, the battery must not be used. Properly dispose of the bad battery.

### LED Description

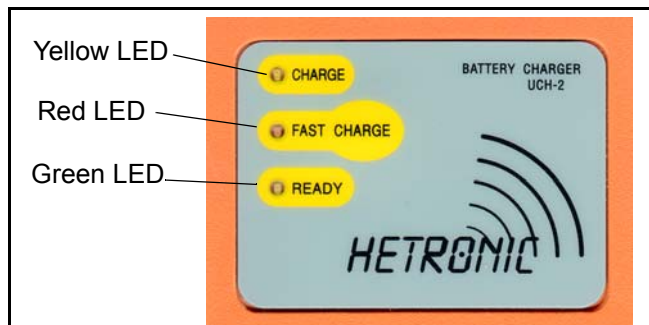

<b>Yellow CHARGE LED</b>	Lights constantly - Charging Continuous flashing - Damaged battery cell (short)
<b>Red FAST CHARGE LED</b>	On - Fast charge in process
<b>Green READY LED</b>	On - Battery fully charged, trickle mode in process
<b>No LED on after battery inserted</b>	Damaged battery cell (open cell)

### Charging the Battery

1. Insert the battery by placing the end with gold-plated contacts into the battery charger cavity.
2. Slide the battery into the battery charger cavity until the battery drops and latches into place.
3. The LED labeled "CHARGE" flashes for two seconds, then stays lit during the charging process.
4. When the battery is fully charged, the "READY" LED lights up and the "CHARGE" LED goes off. Charging time could take up to 5 hours, depending on the condition of the battery.
5. Leave the battery in the charger until it is needed. The charger supplies a "trickle" charge but will not over-charge the battery.

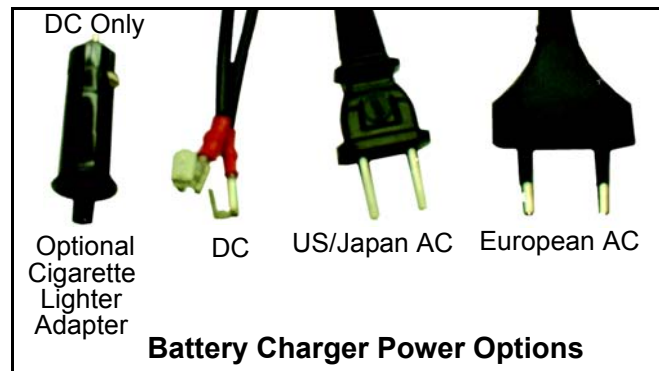
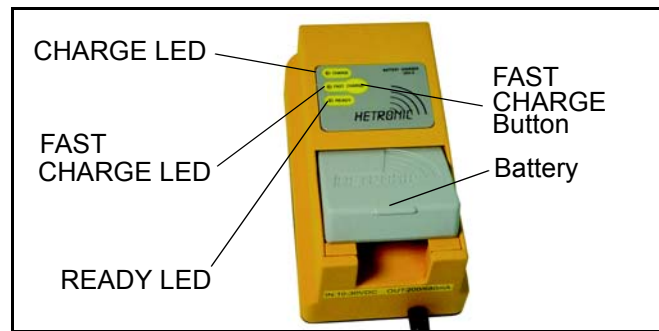

### Fast Charge

1. Insert the battery into the charger as described above. The LED labeled "CHARGE" flashes for two seconds, then stays lit.
2. Press the "FAST CHARGE" button. The FAST CHARGE LED lights also and stays lit during the charge process.
3. When the battery is fully charged, the "READY" LED lights up and the "CHARGE" and "FAST CHARGE" LEDs turn off.

If you have questions or problems operating your battery charger, please contact your dealer or Hetronic.

### Hetronic Battery Information

Standard Hetronic rechargeable batteries are the nickel metal hydride type. These batteries have no "memory effect" when charging a battery that is not fully discharged.



# RF MODULES

## Description of Functions

The transmitter RF Unit comes with an attached RF antenna. The electric connection to the coding electronics is done via Dubox connectors.

The radio module works on one of the 32 different frequencies which are separated into two groups with 16 channels each. The groups are selected via a soldered connection (J3) and the channels are selected via the 10-pin Dubox connector and pin jumpers.

**NOTE:** Disconnect all power to the transmitter and receiver before making any change to the frequency.

## Setting the Frequency Channel

The frequency channel of the transmitter must be set to the frequency channel of the receiver it is going to control. Each Hetricon radio remote control system is pre-set at the factory with the correct frequency channel in the transmitter and receiver. The frequencies may need to be changed if a transmitter, receiver, or RF module of either unit has been replaced. The frequencies of the transmitter and receiver must be identical.

1. Remove the back cover from the transmitter.
2. Locate the RF Module inside the transmitter.
3. Locate the Frequency Channel Jumper Block on the RF module (shown below).

4. Find the correct chart for your RF Module (CS 458, CS 447, CS 434 or CS 402)
5. Set the frequency jumpers on D0, D1, D2, or D3 according to the chart.
  - "ON" means that a jumper should be placed in that position.
  - "OFF" means that that position should be empty.
6. When finished, reinstall the back cover onto the transmitter.

The following diagrams show the transmitter RF module, each channel/frequency and the positions of the jumpers.

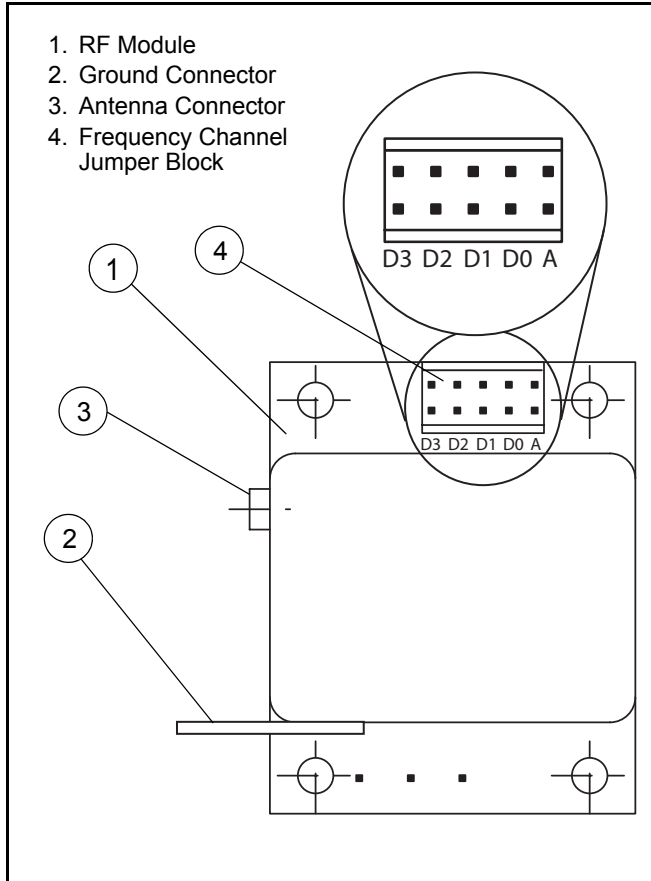

## CS 458 RF-Synthesizer

The frequency range of the CS 458 synthesizer extends from 458.800 MHz to 459.175 MHz. The RF Unit CS 458 is approved for registration-free operation in the USA, and there are no licensing requirements. Other approvals may apply.

 <h1 style="margin: 0;">CS 458 Frequency &amp; Jumper Settings</h1>	<b>Hetronic</b>
	SALS_008.0_CS 458
	May 2003

The Hetronic Radio Remote Control System address code and frequency channel are set at the factory. The address code and frequency channel may need to be set if you have purchased a replacement or spare transmitter.



- Never change the address code or frequency channel of the original transmitter purchased with your system.
- Never change the address code settings in the receiver.
- Never operate two transmitters at the same time that are set with the same frequency channel and address code.

Group USA - Jumper "J3" Open		D0	D1	D2	D3	Group GB - Jumper "J3" Closed	
Channel	Frequency (MHz)					Frequency (MHz)	Channel
A0	458.800	ON	ON	ON	ON	458.525	B0
A1	458.825	OFF	ON	ON	ON	458.550	B1
A2	458.850	ON	OFF	ON	ON	458.575	B2
A3	458.875	OFF	OFF	ON	ON	458.600	B3
A4	458.900	ON	ON	OFF	ON	458.625	B4
A5	458.925	OFF	ON	OFF	ON	458.650	B5
A6	458.950	ON	OFF	OFF	ON	458.675	B6
A7	458.975	OFF	OFF	OFF	ON	458.700	B7
A8	459.000	ON	ON	ON	OFF	458.725	B8
A9	459.025	OFF	ON	ON	OFF	458.750	B9
A10	459.050	ON	OFF	ON	OFF	458.775	B10
A11	459.075	OFF	OFF	ON	OFF	458.825	B11
A12	459.100	ON	ON	OFF	OFF	458.8375	B12
A13	459.152	OFF	ON	OFF	OFF	458.900	B13
A14	459.150	ON	OFF	OFF	OFF	458.825	B14
A15	459.175	OFF	OFF	OFF	OFF	458.900	B15

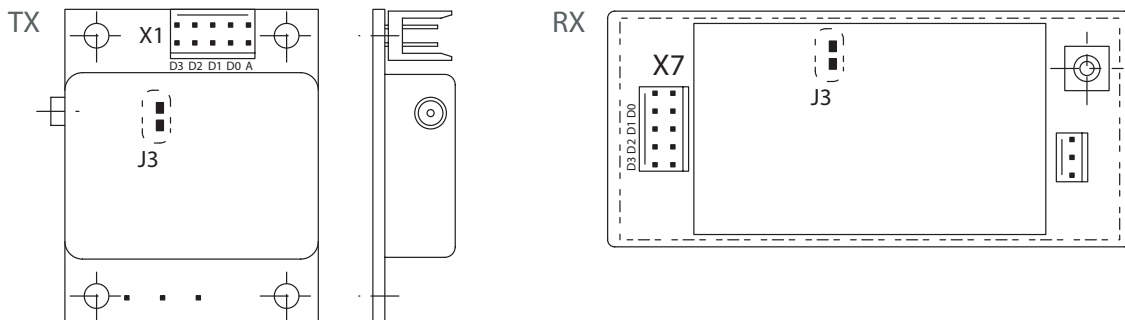

## CS 447 RF-Synthesizer

The frequency range of the CS 447 synthesizer extends from 447.275 MHz to 447.700 MHz. The RF Unit CS 447 is approved for registration-free operation in Korea, and there are no licensing requirements. Other approvals may apply.

	CS 447 Frequency & Jumper Settings	Hetronic
		SALS_011.0_CS 447 May 2003

The Hetronic Radio Remote Control System address code and frequency channel are set at the factory. The address code and frequency channel may need to be set if you have purchased a replacement or spare transmitter.



- Never change the address code or frequency channel of the original transmitter purchased with your system.
- Never change the address code settings in the receiver.
- Never operate two transmitters at the same time that are set with the same frequency channel and address code.

Group A - Jumper "J3" Closed		D0	D1	D2	D3	Group B - Jumper "J3" Open	
Channel	Frequency (MHz)					Frequency (MHz)	Channel
A1	447.8625	ON	ON	ON	ON	447.275	B1
A2	447.8750	OFF	ON	ON	ON	447.300	B2
A3	447.8875	ON	OFF	ON	ON	447.325	B3
A4	447.9000	OFF	OFF	ON	ON	447.350	B4
A5	447.9125	ON	ON	OFF	ON	447.400	B5
A6	447.9250	OFF	ON	OFF	ON	447.450	B6
A7	447.9375	ON	OFF	OFF	ON	447.500	B7
A8	447.9500	OFF	OFF	OFF	ON	447.550	B8
A9	447.9625	ON	ON	ON	OFF	447.600	B9
A10	447.9750	OFF	ON	ON	OFF	447.650	B10
A11	447.9875	ON	OFF	ON	OFF	447.700	B11
A12	447.8750	OFF	OFF	ON	OFF	447.750	B12
A13	447.9000	ON	ON	OFF	OFF	447.775	B13
A14	447.9250	OFF	ON	OFF	OFF	447.800	B14
A15	447.9500	ON	OFF	OFF	OFF	447.825	B15
A16	447.9750	OFF	OFF	OFF	OFF	447.850	B16

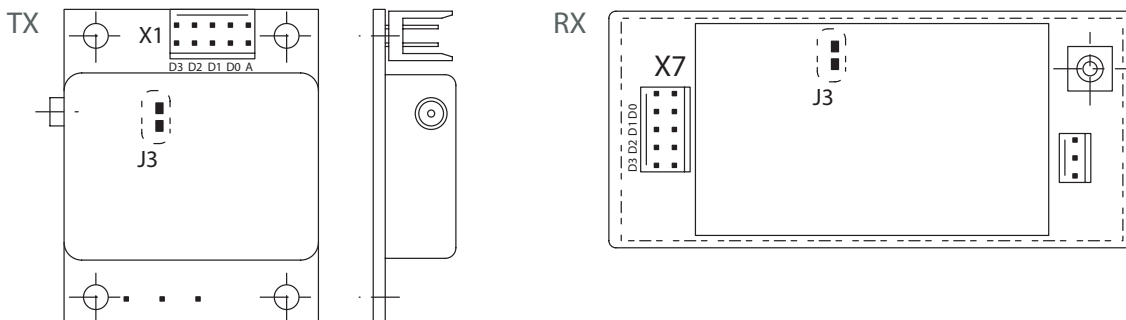

## CS 434 RF-Synthesizer

The frequency range of the CS 434 synthesizer extends from 433.875 MHz to 434.650 MHz. The RF Unit CS 434 is approved for registration-free operation in the EU, Canada, Australia, Asia and the USA, and there are no licensing requirements. Other approvals may apply.

	<h1>CS 434 Frequency &amp; Jumper Settings</h1>	<b>Hetronic</b>
		SALS_009.0_CS 434 May 2003

The Hetronic Radio Remote Control System address code and frequency channel are set at the factory. The address code and frequency channel may need to be set if you have purchased a replacement or spare transmitter.



- Never change the address code or frequency channel of the original transmitter purchased with your system.
- Never change the address code settings in the receiver.
- Never operate two transmitters at the same time that are set with the same frequency channel and address code.

Group A - Jumper "J3" Closed		D0	D1	D2	D3	Group B - Jumper "J3" Open	
Channel	Frequency (MHz)					Frequency (MHz)	Channel
A1	433.875	ON	ON	ON	ON	433.900	B1
A2	433.925	OFF	ON	ON	ON	433.950	B2
A3	433.975	ON	OFF	ON	ON	434.000	B3
A4	434.025	OFF	OFF	ON	ON	434.050	B4
A5	434.075	ON	ON	OFF	ON	434.100	B5
A6	434.125	OFF	ON	OFF	ON	434.150	B6
A7	434.175	ON	OFF	OFF	ON	434.200	B7
A8	434.225	OFF	OFF	OFF	ON	434.250	B8
A9	434.275	ON	ON	ON	OFF	434.300	B9
A10	434.325	OFF	ON	ON	OFF	434.350	B10
A11	434.375	ON	OFF	ON	OFF	434.400	B11
A12	434.425	OFF	OFF	ON	OFF	434.450	B12
A13	434.475	ON	ON	OFF	OFF	434.500	B13
A14	434.525	OFF	ON	OFF	OFF	434.550	B14
A15	434.575	ON	OFF	OFF	OFF	434.600	B15
A16	434.625	OFF	OFF	OFF	OFF	434.650	B16

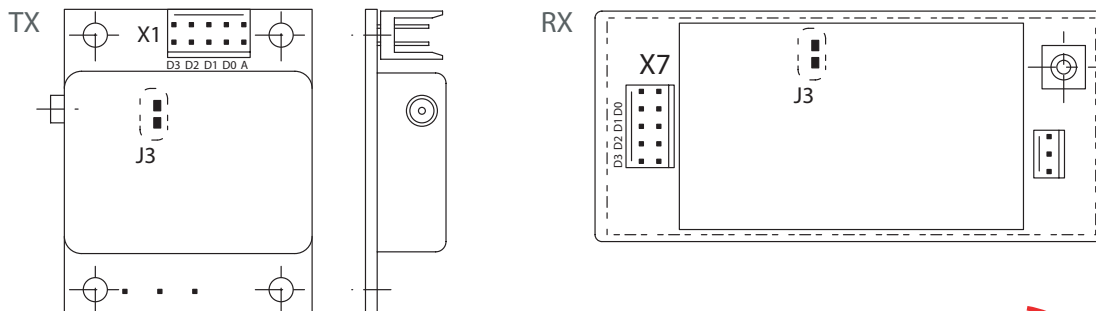

# STD-402 RF-SYNTHESIZER

## Description of the Functions

The frequency range of the STD-402 synthesizer extends from 429.2500 MHz to 429.7375 Mhz. The radio module works on one of the 40 different frequencies. The frequencies can be individually selected, or can be separated into four groups with 10 channels each. The individual frequency or groups are selected via a 6-pin DIP switch array.

**NOTE:** Operation of the RF Unit STD-402R is approved by TELEC for use in Japan, and there are no additional licensing requirements.

**IMPORTANT:** Disconnect all power to the transmitter and receiver before making any change to the frequency.

## Description of the Transmitter Module

The RF unit has a permanently affixed antenna and receives input power and TTL data by the 3-pin Dubox connector (see picture).

## Description of the Receiver Module

Depending on the DIP switch array configuration, the RF Unit continuously scans for valid frequency channels, or scans for an individual frequency. In the continuous scan mode, it locks onto a valid frequency channel once it receives an input signal on the 2-pin Dubox connector (see picture). The RF unit has two SMB diversity antenna inputs. Input power, and TTL signal output, is provided by the 3-pin Dubox connector (see picture).

## Scan Mode

Upon power up, the RF Unit scans for an open frequency channel depending on the DIP switch array configuration. Once an open frequency channel is found, the RF unit locks onto that channel, and begins transmitting data.

## Individual Frequency Mode

Upon power up, the RF Unit checks to see if the individually selected frequency channel is clear. If the frequency channel is clear, the RF unit begins transmitting data. If the frequency channel is not clear, the RF unit will not transmit data.

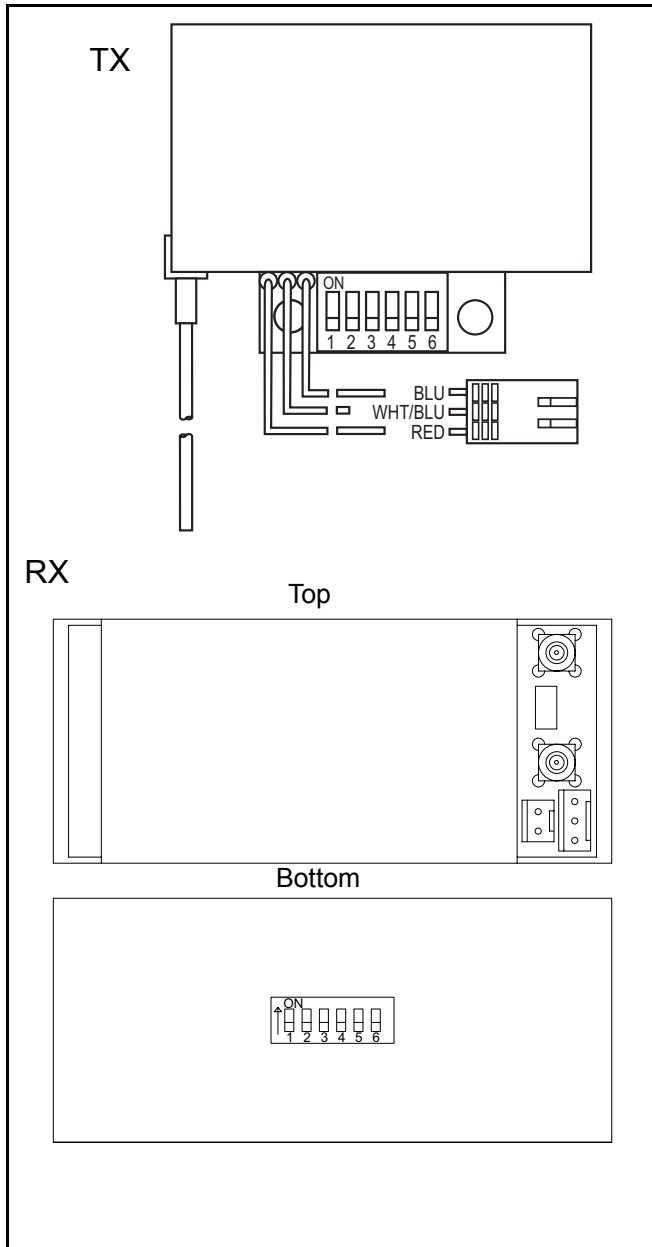

	CS 429 Frequency & DIP Switch Settings	Hetronic
		SALS_010.0_CS 429 May 2003

	Channel	D1	D2	D3	D4	D5	D6	Channel Scan
Scan Mode	0	OFF	OFF	OFF	OFF	OFF	OFF	7, 11, 15, 19, 23, 27, 31, 35, 39, 43
	1	ON	OFF	OFF	OFF	OFF	OFF	8, 12, 16, 20, 24, 28, 32, 36, 40, 44
	2	OFF	ON	OFF	OFF	OFF	OFF	9, 13, 17, 21, 25, 29, 33, 37, 41, 45
	3	ON	ON	OFF	OFF	OFF	OFF	10, 14, 18, 22, 26, 30, 34, 38, 42, 46
	4	OFF	OFF	ON	OFF	OFF	OFF	No function
	5	ON	OFF	ON	OFF	OFF	OFF	No function
	6	OFF	ON	ON	OFF	OFF	OFF	All channels, 7 - 46
Channel	D1	D2	D3	D4	D5	D6	Frequency (MHz)	Scan
7	ON	ON	ON	OFF	OFF	OFF	429.2500	0
8	OFF	OFF	OFF	ON	OFF	OFF	429.2625	1
9	ON	OFF	OFF	ON	OFF	OFF	429.2750	2
10	OFF	ON	OFF	ON	OFF	OFF	429.2875	3
11	ON	ON	OFF	ON	OFF	OFF	429.3000	0
12	OFF	OFF	ON	ON	OFF	OFF	429.3125	1
13	ON	OFF	ON	ON	OFF	OFF	429.3250	2
14	OFF	ON	ON	ON	OFF	OFF	429.3375	3
15	ON	ON	ON	ON	OFF	OFF	429.3500	0
16	OFF	OFF	OFF	OFF	ON	OFF	429.3625	1
17	ON	OFF	OFF	OFF	ON	OFF	429.3750	2
18	OFF	ON	OFF	OFF	ON	OFF	429.3875	3
19	ON	ON	OFF	OFF	ON	OFF	429.4000	0
20	OFF	OFF	ON	OFF	ON	OFF	429.4125	1
21	ON	OFF	ON	OFF	ON	OFF	429.4250	2
22	OFF	ON	ON	OFF	ON	OFF	429.4375	3
23	ON	ON	ON	OFF	ON	OFF	429.4500	0
24	OFF	OFF	OFF	ON	ON	OFF	429.4625	1
25	ON	OFF	OFF	ON	ON	OFF	429.4750	2
26	OFF	ON	OFF	ON	ON	OFF	429.4875	3
27	ON	ON	OFF	ON	ON	OFF	429.5000	0
28	OFF	OFF	ON	ON	ON	OFF	429.5125	1
29	ON	OFF	ON	ON	ON	OFF	429.5250	2
30	OFF	ON	ON	ON	ON	OFF	429.5375	3
31	ON	ON	ON	ON	ON	OFF	429.5550	0
32	OFF	OFF	OFF	OFF	OFF	ON	429.5625	1
33	ON	OFF	OFF	OFF	OFF	ON	429.5750	2
34	OFF	ON	OFF	OFF	OFF	ON	429.5875	3
35	ON	ON	OFF	OFF	OFF	ON	429.6000	0
36	OFF	OFF	ON	OFF	OFF	ON	429.6125	1
37	ON	OFF	ON	OFF	OFF	ON	429.6250	2
38	OFF	ON	ON	OFF	OFF	ON	429.6375	3
39	ON	ON	ON	OFF	OFF	ON	429.6500	0
40	OFF	OFF	OFF	ON	OFF	ON	429.6625	1
41	ON	OFF	OFF	ON	OFF	ON	429.6750	2
42	OFF	ON	OFF	ON	OFF	ON	429.6875	3
43	ON	ON	OFF	ON	OFF	ON	429.7000	0
44	OFF	OFF	ON	ON	OFF	ON	429.7125	1
45	ON	OFF	ON	ON	OFF	ON	429.7250	2
46	OFF	ON	ON	ON	OFF	ON	429.7375	3

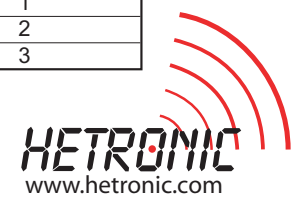

# TROUBLESHOOTING

## QUESTIONS TO ASK

When reporting a problem to Hetronic you may be asked several questions pertaining to the Ergo system. Asking these questions to the person who reported the problem prior to calling Hetronic will speed up the troubleshooting process.

Please locate the Hetronic system labels (example shown below) which is located inside the transmitter battery cavity, and on the side of the receiver. This label contains information that identifies the system.

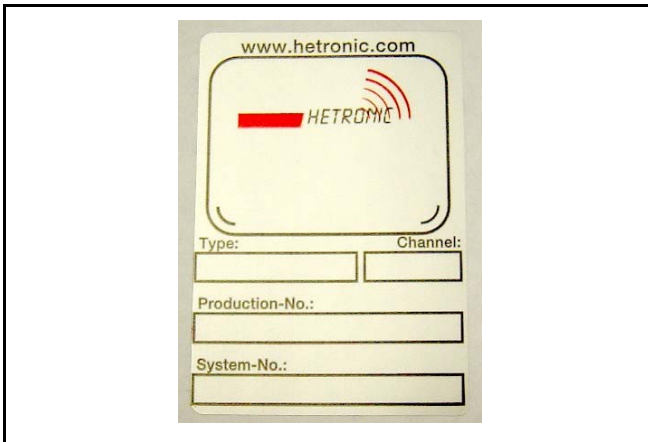

### General

- What is the Production Number and System Number of the transmitter and receiver? This information is provided on the Hetronic system labels.
- Are there other Hetronic systems at or near the machine site?

### Transmitter

- Is the EMERGENCY STOP pushbutton pulled out?
- Is the key switch in the ON position?
- Did you press the START/HORN pushbutton?
- Were the pushbuttons in the off position prior to turning on the transmitter?
- Did you press the START/HORN pushbutton while accidentally holding in one of the other pushbuttons?
- Are the disposable batteries in the battery adaptor pack new, or is there a fully charged optional rechargeable battery pack installed?
- Did you take the transmitter out of its operating range (100 meters)?

### Receiver

Remove the receiver enclosure lid and observe the receiver circuit board. Check the following. Refer to the drawing in the section "Test Procedures" that shows the location of each diagnostic LED.

- Is machine power being applied to the receiver?
- Are any input power fuses blown?
- Is the receiver grounded to the proper machine grounding point?
- Is the yellow CPU LED (LD1) flashing?
- Is the green Telegram LED (LD2) flashing?
- Is the EMERGENCY STOP circuit LED (LD3) flashing?
- Is the EMERGENCY STOP LED (LD5) on the receiver printed circuit board lit?
- Are the connections/screw terminals tight?
- Is the internal antenna securely connected?
- Is the external antenna assembly outside the enclosure securely connected and properly grounded to the machine frame?
- Are all incoming power supply and ground wires properly connected?
- Are the signal wires separated from the high power wires?
- Are surge suppressors installed on any magnetic contactors being controlled by the receiver?

### Warranty Validity

Warranty validity is based on regular inspection and cleaning of the radio remote control equipment.

### COMMON PROBLEMS

The following are common problems associated with using the Hetronic Ergo system, and their possible solutions. For help in diagnosing problems in the receiver, refer to the drawing in the "Test the System" section of this manual that shows the location of each diagnostic LED.

PROBLEM	PROBABLE CAUSE	CORRECTION
<b>System will not initialize after normal start-up procedure</b>	E-Stop switch engaged	Pull out E-Stop switch. Restart system by pressing Start.
	Batteries fully discharged	Check batteries to ensure a full charge. Replace with fully charged batteries if necessary.
	No power to the receiver	Check the diagnostic LEDs in the receiver to be sure power is applied. Ensure that the system is properly grounded.
<b>The transmitter is turned on, but does not transmit (Power LED not flashing)</b>	Battery is discharged	Replace battery with a fully charged battery.
	Broken key switch	Check wiring on key switch. Replace key switch, wiring or contact element.
	Coder board failure	Contact Hetronic or your Dealer.
<b>Transmitter is transmitting (Power LED flashing), but crane/machine will not respond</b>	E-Stop switch engaged	Pull out the E-Stop pushbutton and press the Start/Horn pushbutton
	Transmitter out of range	Take the transmitter back into the range of the receiver. Press the Start/Horn pushbutton.
	A motion function was not in OFF position when transmitter turned on	Ensure that all pushbuttons are in OFF (neutral) position when the Start button is activated.
	Receiver power off	Turn on power to receiver.
	Blown fuse in receiver	Check all fuses. Replace if necessary.
	E-Stop failure in transmitter	Check E-Stop pushbutton for damage. Check wiring to contact element for broken or disconnected wires. Repair or replace E-stop pushbutton or wiring.
	E-Stop failure in receiver. Red E-Stop LED on PCB is illuminated	Contact Hetronic or your Dealer.
	Transmitter/receiver frequency channels do not match	Check frequency settings to be sure transmitter and receiver are set to same frequency channel <b>NOTE:</b> Always match the transmitter frequency channel to the receiver. NEVER change the receiver frequency channel. Contact Hetronic or your Dealer.
	ADMO address codes of transmitter and receiver do not match	Check that the ADMO address code is the same for the transmitter and receiver. Contact Hetronic or your Dealer.



<b>PROBLEM</b>	<b>PROBABLE CAUSE</b>	<b>CORRECTION</b>
<b>All crane/machine motions operate intermittently</b>	Receiver antenna connection is loose or missing	Tighten or replace antenna.
	External antenna (if used) has loose connection, poor grounding or interference	Tighten antenna and ground connection. Contact Hetronic or your Dealer for more information on external antennas.
	Surge suppressors not installed on contactors	Install RC type surge suppressors on all magnetic contactors that are controlled by the radio remote control system
	Control wiring too close to high power machine wiring	Control wiring must be run separately from high power machine wiring.
	Connector inside receiver is loose	Check all connectors, reseal if necessary.
	Another Hetronic transmitter may be interfering with the system. <b>NOTE:</b> This does not apply for STD-402 RF modules	If another Hetronic system is located within 75 meters, the frequency channels must be at least 2 channels apart. If another system is within 20 meters, the channels must be at least 3 channels apart. Contact Hetronic or your Dealer for assistance.
<b>Some crane/machine motions operate intermittently</b>	Crane/machine motion wiring may be loose.	Check wiring from receiver to plug and from plug to crane/machine motion actuator.
	Connector inside receiver is loose	Check all connectors, reseal if necessary.
	Surge suppressors not installed on contactors	Install RC type surge suppressors on all magnetic contactors that are controlled by the radio remote control system
	Control wiring too close to high power machine wiring	Control wiring must be run separately from high power machine wiring.

## SPECIFICATIONS

### ERGO SYSTEM

Operating range	100 m (330 ft.) typical
Frequency range	400 - 470 MHz
Deviation	+/- 2 kHz
HF output power	10 mW max.
Operating temperature range	-25° to +70° C (-18° F to 158° F)
Enclosures	IP65 weatherproof (exceeds NEMA 12/13)
Transmitter antenna	Built-in
TX Weight	Less than 1 lb (400 g) (incl. battery)
TX Size (L, W, H)	200 x 85 x 35 mm 7.8 x 3.4 x 1.4 inches
TX Power supply	Adapter pack with 3 AA 1.5V alkaline batteries or equivalent Optional 3.6V/1200mAh NiMH rechargeable battery pack
Operation time	Up to 20 hours for CS 434 and CS 458 Up to 18 hours for STD 402

### ERGO V1

Functions	E-Stop pushbutton 6 single-speed pushbuttons
-----------	---

### ERGO V2

Functions	E-Stop pushbutton Start/Horn pushbutton 6 single-speed motion pushbuttons 5 single-speed option pushbuttons
-----------	--

### ERGO V4

Functions	E-Stop pushbutton Start/Horn pushbutton 6 2-speed motion pushbuttons 2 single-speed option pushbuttons
-----------	---

### ERGO V5

Functions	E-Stop pushbutton Start/Horn pushbutton 6 2-speed motion pushbuttons 2 single-speed option pushbuttons
-----------	---

### ERGO V7

Functions	E-Stop pushbutton Start/Horn pushbutton 6 2-speed motion pushbuttons 1 3-position slide selector
-----------	---

### ERGO V8

Functions	E-Stop pushbutton Start/Horn pushbutton 6 2-speed motion pushbuttons 2 single-speed latching option pushbuttons
-----------	--

### RECEIVER RX 14

Size	246 x 160 x 90 mm 9.7 x 6.3 x 3.5 inches
Weight	1690 g 3.7 lbs
Operating power	48/110/240 VAC 50/60 Hz (+/- 20%) 12/24 VDC (+/- 20%)
Current	<100 mA
Safety features	Self-monitoring E-Stop circuits Fail-safe, spring forced E-Stop relay Self-test during start-up and operation On-board diagnostic system with indicators for RF communication, power status, active outputs
Outputs	1 NO Potential-free E-Stop relay at 8A 30VDC/240VAC 14 NO Potential-free relays at 8A 30VDC/240VAC

## BATTERY CHARGER

Charging current	Normal: 200 mAh Fast charge: 680 mAh
Charge time (Standard Hetric 1200 mAh battery)	Normal: approx. 6 hours Fast charge: less than 2 hours (no damage to battery, or negative effect to duty cycles)
Temperature range	-20°C to +75°C (-4° F to 167° F)
Power supply	DC - 12-24 VDC, polarity protected AC - 110-220 VAC, US/Japan or EU plug
NOTE: Will also charge 9.6 V batteries. Internal modification and mechanical limiters must be removed.	

## OPTIONAL RECHARGEABLE BATTERY

Battery type	NiMh (nickel metal hydride)
Capacity (typical)	1200 mAh
Typical operation time	20 hours typical with one charge (depending on TX configuration)
Memory effect	None
Duty cycle	Can be recharged at least 500 times (after 500 charges, over 80% of capacity remains and will diminish gradually)

## INSTALLATION AND SAFETY TEST DATA

This form must be completed and signed by the person responsible for installation of this radio remote control system.

Hetronic assumes no responsibility for the correct installation of the radio remote control system. The equipment operator must ensure that the radio remote control system and the crane/machine operate correctly together.

The operator must also ensure that all safety devices and features are in place and operating correctly. The operator is responsible for understanding and following all safety precautions in this and other applicable operator manuals.

<b>Crane/machine Data</b>	
Manufacturer	
Model Number	
Serial Number	
Year of Production	
<b>Radio Remote Control Data</b>	
Manufacturer	Hetronic
Model	
System Type	
Transmitter Production Number	
Receiver Production Number	
System Number	
I/We installed the radio remote control system, performed the safety test and inspected the crane/machine. The appropriate instructions and rules of this crane/machine type are followed.	
Place	
Date	
Company	
Name of Installation Technician	
Signature	

## DEFINITIONS

Acoustic signal	A buzzer or other sound intended to be heard as an alert.
Analog signal	Proportional - stepless or infinite control
Belly box	A transmitter that is secured to the front of the operator's body by a belt, strap or breastplate/harness.
Coder	Converts parallel signals into a serial data message
Decoder	Coverts a serial data message into parallel signals
Digital signal	On/off control
Latching control	The function activates when the control is pushed and released. The function stays on until the control is pushed and released again.
Mainline contactor	The primary power supply contactor to the crane/machine controls.
Maintained control	The function activates when the control is placed in the ON position. The function stops when the control is placed in the OFF position.
Momentary control	The function activates when the control is placed in the ON position. The control must be held in place to stay ON. When the control is released, it returns to the OFF position and the function is stopped.
Proportional control	A multi-speed function control that goes faster as the control is pressed further.

## AWG - METRIC CONVERSIONS

AWG	Metric Equivalent mm sq.	Metric Cable Size mm sq.
20	0.52	0.75
18	0.82	1.0
16	1.32	1.5
14	2.1	2.5
12	3.3	4
10	5.32	6
8	8.5	10
6	13.5	15
4	21.3	25
2	33.7	35
1/0 (0)	53	70.0 (50.0 if current capacity not exceeded)
2/0 (00)	67.6	70
3/0 (000)	84.4	95
4/0 (0000)	107	120

## ABBREVIATIONS

A/D	Analog to digital conversion
AK	Analog channel
AMP	Ampere
AWG	American Wire Gauge
BPS	Bits per second
CPU	Central Processing Unit
DK	Digital channel
EMC	Electromagnetic compatibility
EMI	Electromagnetic immunity
EPROM	Electrical programmable read-only memory
FM	Frequency modulation
GND	Ground
HF	High frequency
KHz	Kilohertz
LED	Light emitting diode
LTO	Lift to operate
mAH	Milliamperere hours
mA	Milliamperere
msec	Millisecond
MHz	Megahertz
MOV	Metal Oxide Varistor type of surge suppressor
mW	Milliwatt
NiCd	Nickel Cadmium
NiMH	Nickel Metal Hydride
PLC	Programmable logic controller
PLL	Phased locked loop
PTO	Press to operate
PWM	Pulse width modulation
R/C	Resistor/Capacitor type of surge suppressor
RF	Radio frequency
RMS	Root mean squared
Rx	Receiver
RxD	Receiving data
SMD	Surface mount device
SMT	Surface mount technology
TTL	Transistor transistor logic
Tx	Transmitter
TxD	Transmitting data
Ub	Operating power
Uv	Microvolts
VAC	Volts alternating current
VDC	Volts direct current

# WARRANTY

	<h2>Limited Warranty and Terms of Sale</h2>	<b>Hetronic USA</b>
		WRTY_002 Warranty & Terms April 2003

Price: Subject to Change Without Notice  
Terms: Net 30 Days  
F.O.B: Hetronic USA, Inc.  
Oklahoma City, Oklahoma

Hetronic, Inc., hereafter referred to as Company, guarantees all items manufactured by it against any defects of material and/or workmanship for a period of one year from the date of shipment. Company makes NO OTHER WARRANTY, EXPRESSED OR IMPLIED, AS TO THE MERCHANTABILITY OR FITNESS OF THE ITEMS FOR THEIR INTENDED USE OR AS TO THEIR PERFORMANCE. Any statement, description or specification in Company's literature is for the sole purpose of identification of items sold by the Company and imparts no guarantee, warranty or undertaking by Company of any kind. Components and accessories not manufactured by Hetronic are not included in this warranty and are warranted separately by their respective manufacturers.

Company's sole liability shall be to repair at its factory, or replace, any item returned to it within one year from date of shipment, which Company finds to contain defective material or workmanship. All items to be repaired or replaced shall be shipped to Company (Note: return authorization by Company is required) within said one year period, freight prepaid, as a condition to repair or replace defective material or workmanship. Company's herein assumed responsibility does not cover defects resulting from improper installation, maintenance, or improper use. Any corrective maintenance performed by anyone other than the Company during the warranty period shall void the warranty. Company shall not be liable for damages of any kind from any cause whatsoever beyond the price of the defective Company supplied items involved. Company shall not be liable for economic loss, property damage, or other consequential damages or physical injury sustained by the purchaser or by any third party as a result of the use of any Company supplied items or materials.

List prices or discounts are subject to change without notice. Quoted prices will be honored for a period of 90 days from the date of the written quotation unless otherwise stated.

Orders are not subject to alteration or cancellation except upon written consent of Company and payment of proper cancellation charges, when deemed applicable by Company.

Materials or items may not be returned for credit, without the prior written consent of the Company. Any authorized return of materials or items shall be subject to a restocking charge equal to 20% of the net invoiced amount after Company determines that the material or item is in good condition and may be resold without alteration or service.

Terms of payment are NET 30 days. All materials and items are sold F.O.B. Company's shipping point. Company retains a security interest in all items sold by it so long as they remain in Company's possession to secure all obligations of purchaser to Company. A processing fee will be applied to all invoices for requested prepaid freight charges other than UPS. A service charge will be incurred on past due accounts extending beyond the terms of sale described above, at a rate of 1.5% per month of the net balance extending beyond 30 days.

The buyer should inspect the goods immediately on their arrival and shall within five days of their arrival give written notice to the Company of the claim that the goods do not conform with the terms of the contract. If the buyer shall fail to give such notice, the goods shall be deemed to conform with the terms of the contract. Any claim for material or item shortages must be accompanied by copies of the bill of lading and packing slip.

Delivery schedules or commitments are based upon current production capacities, material or component availability and inventory and may be changed as conditions require. Company shall not be liable for loss or damage of any kind resulting from delay or inability to deliver on account of fire, labor troubles, accident, acts of civil or military authorities, or from any other cause beyond Company's control.



**HETRONIC**  
www.hetronic.com