

**USER OPERATION AND
INSTALLATION MANUAL**

ES-CAN HL Receiver

USER OPERATION AND INSTALLATION MANUAL

03/2020

www.hetronic.com



Table of Contents

1. Safety	3
1.1 Intended Use	3
1.2 Symbol Notation	3
1.3 Practices and Laws	3
1.4 Required Operator Training	3
1.5 Possible Sources of Danger	3
1.6 Protective Features	4
1.7 STOP in case of EMERGENCY	4
2. Introduction and Functional Description	5
2.1 Production and System Numbers	5
2.2 Before Operating Your Wireless Control Unit	5
2.3 Unit Labels	5
3. Your ES-CAN HL Receiver	6
3.1 General Description	6
3.2 ES-CAN HL Receiver Basic Features	6
3.3 Standard ES-CAN HL Receiver Configurations	6
4. Installation	8
4.1 Pre-Installation Precautions	8
4.2 Step-By-Step Installation	8
4.3 System Testing	9
4.4 Receiver Operation LED Behaviour and Meanings	9
4.5 Cable Control (optional)	9
5. Theory of Operation	10
5.1 Stop Function	10
6. Troubleshooting	11
7. Specifications	12
8. Warranty, Service, Repairs and Maintenance	13
9. Regulatory Information	14
9.1 Europe	14
9.2 North America	14
9.3 Industry Canada (IC/ISED) Statement	15
Appendix A	16
Definition of terms	16
Appendix B	17
B.1 Operator Safety Basics	17
B.2 Safety Checklist	17
B.3 ES-CAN HL Receiver Variants and Current Rating	18

List of Figures

Figure 1. Product Rating Plate	5
Figure 2. ES-CAN HL Receiver with 30pol connector	6
Figure 3. ES-CAN HL Receiver with cable gland	7
Figure 4. Drill pattern for standard ES-CAN HL Receiver	8

List of Tables

Table 1. Operational LED Colour, Behaviour and Meanings	9
Table 2. Troubleshooting tips	11
Table 3. Receiver Technical Specifications	12

1. Safety

1.1 Intended Use

Your radio remote control is designed for remote operation of machines and systems using safe wireless communications technology. Any modification, reconstruction or extension of the systems without a written agreement of Hetronic may lead to the loss of your warranty and guarantee claims.

Hetronic assumes no liability for damages resulting out of the non-observance of this manual. All persons, working with this radio remote control must



- Be adequately trained and qualified as required by the safety regulations.
- Strictly comply with the contents of this operation and installation manual.

Before starting the radio remote control you must have read and fully understood this operation and installation manual. The Safety Checklist in Appendix B is intended to be followed before each time the transmitter is powered up for operation.

1.2 Symbol Notation

The following symbols are used in this manual. The safety alert symbol is used in decals on the unit and with proper operation procedures in this manual.

Understand the safety message. It contains important information about personal safety on or near the unit.

	<p>STOP! This symbol gives you warning of imminent danger of life, risk of accident and risk of injury, as well as damage to property in case of non-observance of the working instructions.</p>
	<p>ATTENTION! This symbol advises against a possible damage to the system in case of non-observance of the working instructions.</p>
	<p>TIP! This symbol points to features and information which allow for an easier handling or operation.</p>

1.3 Practices and Laws

Practice safe working precautions for the benefit of yourself and others.

Be alert to unsafe conditions and the possibility of minor, moderate, or serious injury or death. Learn applicable rules and laws in your area.

1.4 Required Operator Training

The original purchaser of this unit was instructed by the seller on safe and proper operation. If unit is to be used by someone other than original purchaser; loaned, rented or sold, ALWAYS provide this manual and any needed safety training before operation. ALWAYS read and understand the documentation for any machine to be controlled by radio remote control.

1.5 Possible Sources of Danger

This device is part of a system that makes remote control via wireless radio signals possible. The transmission of control commands can take place around obstacles and out of the operator's direct line of sight. Take the following precautions to prevent accidental start-up and possible injury or damage:



Switch "OFF" the transmitter when it is not in use. Unless the transmitter has user access control password configured, remove the battery if unit is placed away from the operator.



Disconnect the power supply from the receiver before any assembly, maintenance or repair work is done.



AVOID SYSTEM DAMAGE - ALWAYS disconnect receiver power supply and control wiring before welding on any part of the machine.



Never remove or alter any of the safety features.



ALWAYS confirm that the machine and radio remote control Stop functions work properly **BEFORE** beginning any machine operation.

1.6 Protective Features

This transmitter is equipped with electronic and mechanical safety features. Control signals from other transmitters cannot be processed because transmission coding is unique to each system.

1.7 STOP in case of EMERGENCY

Push the emergency stop on the machine.

2. Introduction and Functional Description

We congratulate you on the purchase of your new Hetricon ES-CAN HL Receiver. You have chosen a high quality product. Familiarise yourself with the unit before using it for the first time. In addition please carefully refer to the operating instructions and the safety advise given in this manual. Only use the product as instructed and only for the intended field of application. Keep these instructions in a safe place. If you pass the product on to anyone else, please ensure that you also pass on all the documentation with it.

2.1 Production and System Numbers

Before contacting your dealer or Hetricon about service, repair or replacement parts, note the equipment Production and System numbers. These numbers are located on the silver label affixed to the unit.

2.2 Before Operating Your Wireless Control Unit

Confirm that installation of all your system components has been properly completed. Before start up, **ALWAYS** confirm that the machine and radio remote control Stop functions work properly.

Understand all Safety Precautions provided in the manuals and review control functions and operation of the machine and this radio remote control system. When not in use, turn the receiver off and disconnect all power sources to prevent unauthorized use. Ensure that the USB Dongle (which acts as a security key to program the receiver) is kept in a separate but safe and secure place. If the machine does not respond properly, immediately stop operation. Turn off the unit and report the condition to your supervisor.

Turn off the receiver and disconnect all power sources before any maintenance work is done. Installation, setup and service must be performed by authorized and qualified personnel only.

2.3 Unit Labels

2.3.1 Product Rating Plate

1. Specific approvals, such as CE, FCC, IC, etc.
2. Type of receiver
3. Eleven-digit production number
4. Eleven-digit system Number
5. Ingress protection rating
6. Frequency information
7. Supply voltage
8. Current rating

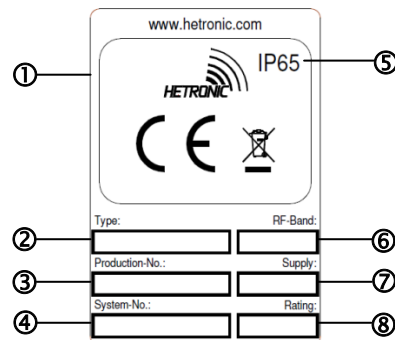

Figure 1. Product Rating Plate

2.3.2 Read User Manual



The “Read User Manual” symbol on the receiver acts as a reminder for the user to thoroughly read through the manual before attempting to operate the system. The User Manual must always be placed in a safe and easily accessible place when not being used for when there is the need to refer to it.

3. Your ES-CAN HL Receiver

3.1 General Description

The ES-CAN HL receiver is a highly programmable radio decoder for industrial remote machine control.

3.2 ES-CAN HL Receiver Basic Features

- Fully programmable via Hetronic PC-Link
- 2 independent CAN interfaces
- 1 onboard radio interface for TR modules
- 1 external radio interface for TRT, TRR or other serial modules
- 1 RS232 interface for cable control and Hetronic PC-Link configuration
- 1 USB device interface for Hetronic PC-Link configuration and software updates
- 2 Main Contact relays
- 2 Change-over output relays
- 4 digital outputs
- 4 analogue inputs
- DK31 and DK32 safety signal outputs
- Supports half duplex and full duplex feedback
- Supports LCD (graphic or text), 16 LED, and 4 LED feedback types
- Feedback via cable control

3.3 Standard ES-CAN HL Receiver Configurations

Your ES-CAN HL receiver can be in one of the following configurations:

A. ES-CAN HL HD/FD with 30pol connector



Figure 2. ES-CAN HL Receiver with 30pol connector

B. ES-CAN HL Receiver with cable gland



Figure 3. ES-CAN HL Receiver with cable gland

4. Installation

4.1 Pre-Installation Precautions

1. Make sure the transmitter and receiver have identical ADMO numbers and channels.
2. Make sure the receiver is not set to the same channel as any other systems in use in the surrounding area.
3. Make sure that the controller or equipment is working properly prior to radio remote control installation.
4. Make sure the power source to the receiver is set correctly.
5. Switch off the main power source to the controller or equipment prior to installation.

4.2 Step-By-Step Installation

1. For the Radio Remote Control to operate smoothly, the receiver should be installed in such a position as to allow the maximum reception of radio waves from the antenna. Thus, for best reception the location of the receiver should be such that it is visible to the operator at all times.
2. The location selection should not be exposed to high levels of electric noise and should not be surrounded by metal or other conductive materials. Mounting the receiver next to an unshielded variable frequency device may cause interference. The metallic parts of the machine to be controlled that surround the receiver create a barrier that interferes with reception of the transmitter signal. Always locate the receiver as far away from variable frequency drives as possible. Sometimes, however, in extreme cases and if the space is inadequate, installation needs to be carried out inside the electrical boards or in areas of the machine that are not ideal for good radio reception. Should this kind of installation be necessary, then the equipment must be provided with an additional antenna using an extension to be placed on the outside. Your dealer will be able to provide further detailed information regarding the most appropriate items specific to the application.
3. Ensure the selected location has adequate space to accommodate the receiver. Always locate the receiver so as to avoid the possibility of damaging the antenna. In most cases, the receiver can be housed on any side of the machine or, if necessary, for installations on vehicles even inside the glass cabin. It is also necessary to place the receiver where it is accessible and safe to work both for those who carry out the installation of the electrical connections and for those who will carry out future maintenance.
4. Depending on the application, the receiver should possibly be installed in such a manner that any connectors or cable plug holes face downwards. Consult with a Hetronic expert for best antenna mounting orientation on your application,



5. Should such an installation be performed on board mobile machinery or on a vehicle, then you should attach four rubber bumpers that can be ordered directly from your Hetronic dealer, unless already supplied as standard fittings on the radio control type in use. These rubber bumpers will dampen the strong vibrations coming from the machine from reaching the receiver.
6. Determine the position where the enclosure is to be mounted and drill the holes as per diagram below.

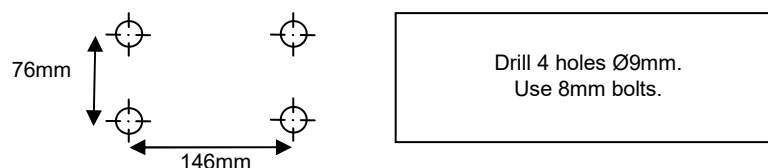

Figure 4. Drill pattern for standard ES-CAN HL Receiver

7. Insert the bolts through each of the four mounting holes and make sure they are tightened well.
8. Connect the connection cables as per machine/system drawings.

4.3 System Testing

1. Turn on the power source to the receiver and test the MAIN relay output by pressing the Remote Stop button on the transmitter. Observe that it properly opens and closes the main contactor.
2. Test the operation of each function to ensure it corresponds to the symbol described by the label next to the function under test.
3. Test the limit switches, if any, to see if they are working properly.
4. If your new remote control is replacing an existing one, make sure the redundant one is completely disconnected and placed in a safe location to prevent unwanted control commands.

4.4 Receiver Operation LED Behaviour and Meanings

The following table gives the meanings for the different behaviours of the Operation LEDs.

LED	Behaviour	Meaning
Status	Blinking 150ms	Software running
	Solid	Software halt
Communication	Blinking	Toggles as valid telegrams are received
	Off	Communication timeout
Error (Red)	Off	No Error
	1xBlink	Stop CPU Comm Error
	2xBlink	ADMO Config Error
	3xBlink	RF Module Error
	Continuous Blinking	Main Contact Error
Main Contact	Off	Main Contact Open
	On	Main Contact Closed
	Blinking	Main Contact Error
CAN Status	On	CAN Bus Operational
	Blinking	Can Bus Preoperational
CAN Error	Off	No CAN Bus Error
	Blinking	CAN Bus Error

Table 1. Operational LED Colour, Behaviour and Meanings

4.5 Cable Control (optional)

The ES-CAN HL receiver can be used either wirelessly or via cable control. When the tether is connected, all wireless communication will be disabled and the telegram will be sent via the cable through the RS232 or CAN bus, depending on the chosen configuration. A number of standard and customized cable options are available to choose from depending on the application. Contact your nearest Hetric representative to discuss the most appropriate solution for you.

5. Theory of Operation

Your ES-CAN HL receiver transfers user control commands received from the paired transmitter via radio waves to your machine. The transmitter electronically generates a carrier frequency that allows it to communicate with the receiver without the use of cables or wires. The receiver then converts the carrier frequency information into discrete machine control outputs that interface with your machine's controls. Each transmitter and receiver that comprises a system is programmed with a unique address code. This code ensures that machine operations are safe, and that other remote control equipment cannot unintentionally control your machine. The receiver only accepts commands from the transmitter with the same address code. The receiver and transmitter address code is configured at factory stage.

5.1 Stop Function

The most important feature of the radio remote control system is the STOP function. When the transmitter is turned on, it performs a self-test to confirm that communications are within designated parameters. If an error is detected, the transmitter will not transmit any signals. The transmitter sends the STOP pushbutton status along with the specified machine functions. This method confirms that ongoing operations are safe. If the STOP pushbutton is pressed, the data telegram changes so that only the stop command is transmitted. No other motion command data is sent.

This special data telegram places the receiver in Safe Mode, and the stop relays in the receiver open. All other machine functions are completely disabled in the receiver.

The STOP button on the transmitter is only a remote stop and will operate only when the transmitter is powered up.



Pressing the STOP pushbutton does not ensure the machine will come to a complete stop. STOP button functionality is subject to the wiring of receiver STOP relays to machine emergency stop circuit and controlled machine logic where applicable.

ALWAYS test the STOP function at the beginning of every operation session or when there is change of operator.

6. Troubleshooting

If your ES-CAN HL receiver does not operate as required, follow the recommended troubleshooting sequence to help isolate the cause and determine corrective action. If you need more information, contact your nearest Hetronic dealer.

PROBLEM	PROBABLE CAUSE	CORRECTION
Receiver does not power up	No power to the receiver	Check the diagnostic LEDs in the receiver to be sure power is applied. Ensure that the system is properly grounded
	Incorrect input voltage supplied	Check input voltage. Check requirements on drawings
	Blown fuse in receiver	Check all fuses and replace if needed
	Incorrect wiring	Check input voltage connections
Transmitter is transmitting (Power LED flashing), but machine will not respond	No power to the receiver	Check the diagnostic LEDs in the receiver to be sure power is applied. Ensure that the system is properly grounded
	Transmitter/receiver frequency channels do not match	Follow instructions under "Setting Frequency and channels" or contact your supervisor
	Transmitter out of range	Take the transmitter back into the range of the receiver, press START
	Receiver power off	Turn on power to receiver
	Blown fuse in receiver	Check all fuses and replace if needed
	STOP failure in receiver. Red STOP LED on PC board is illuminated	Contact your supervisor
All machine motions operate intermittently	Receiver antenna connection is loose or missing	Tighten or replace antenna
	External antenna (if used) has loose connection, poor grounding or interference	Tighten antenna and ground connection. Contact Hetronic or your Dealer for more information
	Connector inside receiver is loose	Check all connectors, reseal if needed
	Another frequency may be interfering with the system	Contact your supervisor
Some machine motions operate intermittently	Receiver antenna connections may be loose to those specific machine motions	Check connections from the receiver to the machine motions
	Connectors inside receiver are loose	Check all connectors, reseal if needed
	Receiver antenna connection is loose or missing	Tighten or replace antenna
Outputs do not correspond to transmitter functions	Incorrect output connections	Check system wiring. Refer to output connection diagram

Table 2. Troubleshooting tips

7. Specifications

ES-CAN HL Receiver	
Housing	Impact Resistant Polymer Composite
Environmental Protection	IP 65 (Exceeds Nema 12/13)
Weight	Max. 650g
Dimensions	Height: 131mm (5.16in.) excl. antenna
	Width: 166mm (6.54in.)
	Depth: 88mm (3.46in.) incl. rubber feet
Antenna	External via TNC connector
Power Supply Voltage Range	12-24Vdc ±50%, 3A max
Diagnostics	Status LED for operation
Operating Temperature Range	-20°C . . . 70°C (-4°F . . . 158°F)
Storage Temperature Range	-40°C . . . 85°C (-40°F . . . 185°F)
Frequency Range	4xxMHz or 8xxMhz or 9xxMHz or 1.216GHz or 2.4GHz (subject to purchased configuration) *
Power (RF Output)	Typically ≤ 10 mW E.I.R.P; depends on country legislation
Typical Operating Range	Typically 120 m. (400 ft.) for ≤ 1GHz, 50-60m (170 ft) for ≥ 1GHz
Safety	20-bit programmable address concept with up to 1,000,000 combinations
	Hamming Distance 4
Humidity Range	95% IEC 60068-2-78
Outputs	2x Main Contact Safety Relay (250Vac/8A max)
	2x Relay Output (SPDT, 250VAC/30Vdc/5A max)
	4x Digital Output (24Vdc/15mA max)
	1x Optional Output Supply (5Vdc/750mA max)
	1x DK31 Safety Signal (5Vdc/15mA max)
	1x DK32 Safety Signal (5Vdc/15mA max)
	1x RS232 Interface
	1x USB Device Interface
Inputs	2x CAN Bus (1.5kV isolation optional)
	2x Main Contact Relay Input (250Vac/8A max)
	2x Relay Input (250Vac/30Vdc/5A max)
	4x Analog Inputs (0-5V Analog or 0-24V Digital)
	1x Optional Input Supply (5-24Vdc/750mA max)
	1x RS232 Interface
	1x USB Device Interface
Serial Interfaces	2x CAN Bus (1.5kV isolation optional)
	1x Digital Output Supply (3-24Vdc external or 5V internal)
	1x RS232 Interface
	1x USB Device Interface
Standard Features	2x CAN Bus (1.5kV isolation optional)
	Fully programmable via Hetronic PC-Link using RS232 or USB ports
	Supports both Half and Full Duplex feedback
	Supports LCD (Graphic or Text), 16LED (LFB) and 4LED feedback
	Feedback also supported over cable control
Up to four transmit and four receive messages per CAN interface	
Up to 12 Logic Gates with up to 12 inputs each	

Table 3. Receiver Technical Specifications

* for full Channel Lists refer to Frequency Bands Radio Modules Charts

8. Warranty, Service, Repairs and Maintenance

Before any service or maintenance intervention on remote controlled equipment always:

- Remove all electrical power from the equipment
- Follow lock out procedures

Hetronic products are covered by a guarantee/warranty against material, construction and manufacturing faults. During the guarantee/warranty period, Hetronic may replace the product or faulty parts. Work under guarantee/warranty must be carried out by Hetronic, or by an authorized service centre specified by Hetronic. Any modification, reconstruction or extension of the systems without a written agreement of Hetronic may lead to the loss of your warranty and guarantee claims.

The following are **not** covered by the guarantee/warranty:

- Faults resulting from normal wear and tear of switching components
- Consumables e.g. batteries
- Products that have been subject to unauthorized modifications
- Faults resulting from incorrect installation and use

Maintenance and Preventive Care

- Repairs and maintenance must be carried out by qualified personnel
- Only use original Hetronic spare parts
- Contact your representative for service or any other assistance
- Keep the product in a clean, dry place
- Keep connector pinouts clean
- Wipe off dust using a slightly damp, clean cloth
- Keep rubber over-mould clean
- Remove dust from inside gaps, connectors and contacts using a vacuum. Special care must be taken when cleaning the housing as detachment of the pressure balance element may lead to ingress protection problems

NEVER USE:

- Abrasive cleaning solutions or high-pressure water jets.
- Sharp, pointed objects or any hard items as these may tear the labels and gaskets.
- Compressed air as this may lead to ingress protection issues.
- Petroleum based solvents including Diesel and Gasoline to clean the unit as these may react with the silicone rubber of the gasket/seal.

9. Regulatory Information

9.1 Europe

CE Marking

Hetronic hereby declares that the safety component "Radio Remote Control Receiver Type RX ES-CAN-HL" types listed in this manual are in compliance with Directive 2006/42/EU article 2(c) and are designed for installation on machinery or other devices. Furthermore, the listed safety component meets the following relevant directives at the time of delivery from the Hetronic manufacturing facilities:

Machinery Directive	2006/42/EU
RED Directive	2014/53/EU

The latest version of the complete EU Declaration of Conformity is available on the Hetronic website www.hetronic.com.

WEEE Directive



This symbol means that inoperative electrical and electronic products must not be mixed with household waste. The European Union has implemented collection and recycling system for which producers are responsible. For proper treatment, recovery and recycling, please dispose of the product in a designated collection point.

REACH Compliance

Hetronic confirms that, to the best of its knowledge and continual communication with its respective suppliers, chemical Substances of Very High Concern (SVHC) are not included in our products. Based on the response statements of our suppliers no materials from the ECHA are included on Hetronic products. For the latest version of the complete Declaration of Conformity please visit the Hetronic website www.hetronic.com.

RoHS Compliance

As a designer and manufacturer of electrical and electronic products covered by RoHS, RoHS2 and RoHS3, Hetronic confirms that to the best of its knowledge at the date of this statement, none of the products supplied by it contain any of the hazardous substances in excess of permitted levels referred to in the Directive 2002/95/EC. The latest version of the complete Declaration of Conformity is available on the Hetronic website www.hetronic.com.

9.2 North America

California Proposition 65

As a designer and manufacturer of electrical and electronic products, Hetronic confirms that to the best of its knowledge at the date of this statement, none of the products supplied by it contain any of the hazardous chemicals listed on California's Safe Drinking Water & Toxic Enforcement Act of 1986 (commonly known as California Proposition 65).

FCC Recommendations:

This device complies with Part 15 of the FCC Rules. Operation is subject to the following two conditions:

1. This device may not cause harmful interference, and
2. This device must accept any interference received, including interference that may cause undesired operation.

Changes or modifications not expressly approved by the manufacturer could void the user's authority to operate the equipment.

To comply with FCC RF exposure compliance requirements, this device and its antenna must not be co-located with, or operating in conjunction with, any other antenna or transmitter.

This equipment has been tested and found to comply with the limits for a Class B digital device, pursuant to Part 15 of the FCC Rules. These limits are designed to provide reasonable protection against harmful interference when the equipment is operated in a residential environment.

This equipment generates, uses, and can radiate radio frequency energy and, if not installed and used in accordance with the instructions, may cause harmful interference to radio communications. However, there is no guarantee that interference will not occur in a particular installation. If this equipment does cause harmful interference to radio or television reception, which can be determined by turning the equipment off and on, the user is encouraged to try to correct the interference by one or more of the following measures:

- Reorient or relocate the receiving antenna
- Increase the separation between the equipment and receiver
- Connect the equipment into an outlet on a circuit different from that to which the receiver is connected.
- Consult the dealer or an experienced radio/TV technician for help.

9.3 Industry Canada (IC/ISED) Statement

IC RF Exposure Statement

This device meets the IC requirements for RF exposure in public or uncontrolled environments.

IC Warning

This product complies with Industry Canada's licence-exempt RSS standards. Operation is subject to the following two conditions:

1. This device may not cause interference, and
2. This device must accept any interference, including interference that may cause undesired operation of the device.

www.hetronic.com



© 2020 Hetronic

All rights reserved. No part of this publication may be reproduced, transmitted, transcribed, stored in a retrieval system, or translated into any language in any form by any means without the written permission of Hetronic.

Technical information subject to change without notice.

Hetronic reserves the right to discontinue, make changes to, and add improvements upon its products at any time without public notice or obligation. Hetronic disclaims liability for any claims or damages, whether regarding property, personal injury or death arising out of the use of unauthorized replacement parts or service.

Appendix A

Definition of terms

The following terms are used throughout this user manual and may be unfamiliar to some operators.

Term	Definition
baud rate	The speed of data transmission measured in bits per second.
base address	The base address is the Hetric PC-Link assigned address of the coder/decoder.

Appendix B

B.1 Operator Safety Basics

Before starting your shift, make sure that the equipment has a current inspection certificate and that the necessary inspections and risk assessment checks have been carried out and are up to date. Also, the equipment must be operated in accordance with the manufacturer's instructions.

Furthermore, it is of utmost importance that you know that **YOU are primarily responsible for YOUR OWN health and safety**. Wear appropriate Personal Protective Equipment and make sure that you have had all the necessary training to operate the equipment. The following basic safety precautions must be adhered to at all times:

1. Transmitter switches must never be mechanically blocked ON or OFF for any motion. When not in use the transmitter must be turned off. A safe and secure storage space should be provided for the transmitter unit and the unit should always be placed there when not in use. This precaution will prevent unauthorized people from operating the crane. Receivers must be removed from the equipment when it is unlikely that it will be used for a period of time, and properly stored.
2. All defective or missing safety equipment, mechanical or electrical defects must be reported to the supervisor without delay. Operation must not continue until all required repairs are completed. Any changes to the condition of the remote or equipment must be recorded and communicated to or made accessible by the following operators on shift.
3. Ensure that there is nobody in the path of the travel of the equipment. If there is, stop and sound the alarm before proceeding.
4. When leaving the equipment area for any reason, switch off the transmitter, remove the key cap and store it in a safe and secure place to prevent unauthorized operation. Unplug the power supply to the receiver.
5. Do not allow any unauthorized person to operate the transmitter at any point.
6. Do not operate the transmitter at a distance where the equipment and all surrounding objects are not visible. Make sure that your view is not obstructed.
7. Do not attempt to override any of the safety features built into the Radio Remote Control.
8. Put rechargeable batteries on charge at the end of each shift.
9. Use protective gloves when surface temperature of unit exceeds 58°C (136°F) as per IEC 62368-1:2014.

B.2 Safety Checklist

The following checklist provides general safety guidelines for radio control operation of equipment by fully qualified and trained operators. These recommendations do not take precedence over any of the following requirements relating to cranes, hoists, lifting devices or other equipment which use or include Hetronic products:

- Instructions, manuals, and safety warnings of the manufacturers of the equipment where Hetronic products are used,
- Plant safety rules and procedures of the employers and the owners of the facilities where the Hetronic products are being used,
- Occupational Health and Safety Administration (OSHA) regulations,
- Safety standards and practices for the industries in which Hetronic products are used.

Receiver Start-up and Safety Checklist		
1	Are screws/bolts fully tightened?	
2	Is the receiver housing free from cracks and damages?	
3	Are the control, connection and antenna cables free from kinks and damages?	
4	Is the STOP function working as it should be?	
5	Is the antenna properly tightened and placed in the correct position/orientation?	
6	Are the cables inserted correctly and glands/seals tightened enough such that no water ingress is possible?	
7	Is the correct input voltage to be supplied?	
8	Are the wires connected to the correct pin-outs/connections?	
9	Are there any metal structures in the vicinity of the antenna?	

B.3 ES-CAN HL Receiver Variants and Current Rating

7410WXYZ.A

W		X		YZ	
1	Half Duplex	0	Not used	00	with 30pol connector (ver 1)
2	Full Duplex			05	with 30pol connector, without logo
				10	with cable gland (ver 2)

The table below shows how the item number of an ES-CAN HL receiver unit is broken down and explains what each digit refers to with regards to different features available on the standard receiver. The suffix '.A' denotes version number.

Item number	Description	W		X	YZ			Current Rating
		1	2	0	00	05	10	
74101000.A	RX ES CAN HL Receiver	✓		✓	✓			750mA
74101005.A	RX ES CAN HL without logo	✓		✓		✓		750mA
74101010.A	RX ES CAN HL ver.2	✓		✓			✓	750mA
74102000.A	RX ES CAN HL FD		✓	✓	✓			750mA
74102010.A	RX ES CAN HL FD ver. 2		✓	✓			✓	750mA